

Proposal Number: 2021-OA-001

Rule 2-005 c) iii)

Description of Change: Amend existing Rule 2-005 to clarify that installations which fall within the scope of section 38 are not included in the exemption.

Background & Rationale:

As new technologies and equipment continue to become available and elevators in dwelling units become more prevalent, the exclusion of 2-005 appears to contradict if equipment installed in dwelling units is exempt when used with elevating devices if it is connected to the load side of a class 2 power supply. Packet energy, control systems and LED lighting are exponentially expanding the options for manufacturers and designers of elevating products. As the nature of these systems need to be installed in a robust manner there is inherent value in the requirements of the Ontario Electrical Safety Code to apply to all aspects of the installation and not just the line voltage wiring, which is identified in 2-005 h).

Proposed Change:

Amend Rule 2-005 as follows

2-005 Notification not required

c) for the installation of wiring and associated equipment connected to the load side of an approved Class 2 power supply or a limited power supply (LPS) whose output does not exceed Class 2 power supply limits by an employee or agent of the original equipment manufacturer or a worker in accordance with his/her designation when the wiring is

i) installed in an owner-occupied dwelling unit;

ii) not connected to electrical equipment identified in Subrule 2-022 3); and

iii) not connected to electrical equipment forming part of an electrical installation to which

Sections 30, 32, 38, and 68 of this Code apply;

Proposal Number: 2021-OA-002

Rule 4-004 26)

Description of Change: Service and feeder conductors size for single dwelling units

Submitted by: Electrical Safety Authority

Background

Rule 4-004 22) and Table 39 in the CE Code 2018 has been deleted. Rule 4-004 22) permits service conductors for single dwellings and feeder conductors supplying single dwelling units of row housing, apartment, or similar buildings to be sized in accordance with Table 39. This represented an easement to the industry by permitting smaller sized conductors for the above prescribed services and feeders compared to other occupancies required to follow Tables 1 to 4.

The provided rationale for the change explains that Table 39 “*creates unwarranted confusion to the Code users*” and that “*some ampacities of conductors listed in Table 39 are lower than the calculated load*” and “*some ampacities are lower than permitted by Table 13*”. The rationale did not provide any evidence that service or feeder conductors were overloaded or presented any safety hazard when sized in accordance with Table 39. There was no rationale provided explaining why larger conductors are now required compared with smaller conductors permitted and used for decades. This proposed deletion of Table 39 can add unjustified burden to the industry.

Rationale

The proposed Ontario amendment to add new subrule Rule 4-004 26) and keep Table 39, intends to continue permitting the smaller size of service conductors for single dwellings and feeder conductors supplying single dwelling units of row housing, apartment, or similar buildings. In order to avoid confusion, it will no longer require additional marking and will not be in contradiction with Table 13 since conductors are required to have 90 °C insulation rating.

This permission and the intent has been largely harmonized with National Electrical Code. (NEC).

**The OESC 28th Edition
Proposals for Ontario Amendments**

Proposed Change:

Add new Subrule Rule 4-004 26) and Table 39

26) Notwithstanding Rules 4-006 and 8-200 1) b), 3-wire 120/240 V and 120/208 V service conductors **or cables** for single dwellings and feeder conductors **or cables** supplying single dwelling units of row housing, apartment, or similar buildings shall be permitted to be sized in accordance with Table 39, if **conductors they** have a 90 °C insulation rating and the maximum calculated load or demonstrated load does not exceed the 75°C ampacity of the conductor in accordance with Rule 8-104 and 8-106.

Table 39 Minimum permitted size for 3-wire 120/240 V and 120/208 V service conductors or cables for single dwellings and feeder conductors or cables supplying single dwelling units of row housing, apartment, or similar buildings [See Rule 4-004 26).]				
Overcurrent device rating, A	Conductor size, AWG or kcmil, Copper 90 °C	Maximum load (A)*	Conductor size, AWG or kcmil, Aluminum 90 °C	Maximum load (A)*
100	3	100	2	9590
125	2	115	1/0	120
200	2/0	175	4/0	180
225	3/0	200	250	205
400	500	380	700	375
400	2 x 2/0	350	2 x 4/0	360

*Loads calculated in accordance with **the applicable Rules in** Section 8 are permitted to exceed these values by 5%.

Proposal Number: 2021-OA-003

Rule 10-611

**Description of Change: Delete existing Ontario Amendment to CE Code Rule 10-611
Submitted by: Electrical Safety Authority**

Background & Rationale:

Rule 10-612 in the CE Code 2021 has been added to adopt the wording from OESC 2018 Rule 10-611 and the amendment is no longer required.

Proposed Change:

Delete Rule 10-611

~~10-611 Installation of equipment bonding conductors~~

- ~~1) The bonding conductor for equipment shall be permitted to be spliced or tapped, but such splices or taps shall be made only within boxes, except in the case of open wiring where they shall be permitted to be made externally from boxes and shall be covered with insulation.~~
- ~~2) Where more than one bonding conductor enters a box, all such conductors shall be in good electrical contact with each other by securing all bonding conductors under bonding screws, or by connecting them together with a solderless connector and connecting one conductor only to the box by a bonding screw or a bonding device, and the arrangement shall be such that the disconnection or removal of electrical equipment fed from the box will not interfere with, or interrupt, the bonding continuity.~~
- ~~3) Where a bonding conductor is run in the same raceway with other conductors of the system to which it is connected, it shall be insulated, except that where the length of the raceway does not exceed 15 m and does not contain more than the equivalent of two quarter bends, an uninsulated bonding conductor shall be permitted to be used.~~
- ~~4) Where a metal raceway or steel pipe is used as a bonding conductor, the installation shall comply with Section 12.~~
- ~~5) A copper bonding conductor shall
 - ~~a) if No. 6 AWG or larger and attached securely to the surface on which it is carried, be protected where exposed to mechanical damage; or~~
 - ~~b) if smaller than No. 6 AWG, or if the installation does not come within the provisions of Item a) of this Subrule, be installed and protected in the same manner as the circuit conductor for a given installation.~~~~
- ~~6) An aluminum bonding conductor shall
 - ~~a) if No. 4 AWG or larger and attached securely to the surface on which it is carried, be protected where exposed to mechanical damage; or~~
 - ~~b) if smaller than No. 4 AWG, or if the installation does not come within the provisions of Item a) of this Subrule, be installed and protected in the same manner as the circuit conductor for a given installation.~~~~
- ~~7) Where a separate bonding conductor is required by this Code to supplement the bonding afforded by a metal raceway, it shall be installed in the same raceway as the circuit conductors.~~
- ~~8) Where a separate bonding conductor, required by this Code, is run with single-conductor cables, the bonding conductor shall follow the same route as the cables.~~

The OESC 28th Edition Proposals for Ontario Amendments

Proposal Number: 2021-OA-004

Rule 12-022

Description of Change: Delete existing Ontario Amendment to CE Code Rule 12-022

Submitted by: Electrical Safety Authority

Background & Rationale:

Rule 12-022 in the CE Code 2021 has been added to adopt the wording from OESC 2018 Rule 12-022 and the amendment is no longer required.

Proposed Change:

Delete Rule 12-022

~~12-022 Cables and raceways installed in metal corrugated roof decking~~

~~Cables or raceways installed in accordance with this Section shall not be installed in concealed locations within corrugated roof decking.~~

Proposal Number: 2021-OA-005

Rule 20-030

Description of Change: Delete existing Ontario Amendments to address Cylinder Exchanges

Submitted by: Electrical Safety Authority

Background:

Previously, Cylinder exchanges were not addressed in Section 20. In order to address cylinder exchanges, the following Ontario Amendments were added

- Rule 20-030 clarifying rules 20-033-20-042 apply to cylinder exchanges;
- Rule 20-032 definition for cylinder exchanges; and
- Rule 20-034 was amended to indicate hazardous location around cylinder

In CE Code 2021, Table 63 note clarifies that Park K applies to Cylinder Exchanges and it is a Zone 2 location for 1.5m making these modifications unnecessary. Cylinder exchange is referenced multiple times by CSA B149.2 and does not need to be defined in the OESC.

Proposed Change:

Delete Ontario Amendment to Rule 20-030, 20-032, 20-034

Delete CE Code Rule 20-030 and replace with the following:

~~20-030 Scope~~ (see Appendix B)

Rules 20-032 to 20-042 apply to locations in which propane is stored, dispensed, or transferred to the fuel tanks of self-propelled vehicles or to portable containers and to locations in which propane is stored or transferred from rail cars or tanker vehicles to storage containers.

20-032 Special terminology

Add the following definition:

~~Cylinder exchange~~—*a facility where propane in refillable cylinders is sold or otherwise distributed to an end user, with cylinders stored in no more than four (4) cabinets and each cabinet containing no more than 227 kg (500 lb) of propane.*

Delete CE Code Rule 20-034 and replace with the following:

~~20-034 Hazardous areas~~

1) In container storage or refill centres and in filling plants, the hazardous areas shall be classified as listed in Table 63.

2) Electrical equipment within 1.5 m of facility cylinder exchange cabinets and extending in all directions shall be approved for Zone 2 locations.

The OESC 28th Edition Proposals for Ontario Amendments

Proposal Number: 2021-OA-006

Rules 64-000 1), 64-002 and 64-900 to 64-908

Description of Change: Delete existing Ontario Amendment to CE Code Rule 64-000 1), Rule 64-002 Special Terminology – ESS and 64-900 to 64-908

Submitted by: Electrical Safety Authority

Background & Rationale:

Rule 64-000 1) and 64-002 in the CE Code 2021 has been revised to adopt the wording and/or special terminology from OESC 2018 Rule 64-000 1) and 64-002 rendering these amendments no longer required.

Rules 64-900 to 64-928 in the CE Code 2021 have been added that cover the requirements in the OESC 2018 Rules 64-900 to 64-908

Proposed Change:

The OESC 28th Edition Proposals for Ontario Amendments

Delete Rule 64-000 1)

~~1) This Section applies to the installation of renewable energy and energy storage systems except where the voltage and current are limited in accordance with Rule 16-200 1) a) and b).~~

Delete Special Terminology 64-002 - ESS

~~Energy storage systems (ESS) — equipment or systems that receive electrical energy and provide a means to store that energy in some form for later use in order to supply electrical energy when needed.~~

~~Energy storage systems, self contained — energy storage systems where the components such as cells, batteries, or modules and any necessary controls, and ventilation, illumination, fire suppression, or alarm systems are assembled, installed, and packaged in a single energy storage container or unit.~~

~~Energy storage systems, other energy storage systems that are not self contained but are individual devices assembled as a system.~~

Delete Rules 64-900 to 64-908

~~Energy storage systems~~

~~64-900 General (see Appendix B)~~

~~Rules 64-050 to 64-078 shall apply to energy storage systems, except where otherwise specified.~~

~~64-902 Interactive point of connection~~

~~The output of interactive energy storage systems shall be permitted to be connected in accordance with Rule 64-112.~~

~~64-904 Voltage of energy storage systems~~

~~Energy storage systems with maximum voltages higher than 750 V dc but not exceeding 1500 V dc shall not be required to comply with Rules 36-204, 36-208, and 36-214 provided that~~

- ~~a) the installation is serviced only by qualified persons;~~
- ~~b) the part of the installation exceeding 750 V dc is inaccessible to the public; and~~
- ~~c) enclosures in which circuits exceeding 750 V dc are present are marked with the word "DANGER" followed by the maximum rated circuit voltage of the equipment.~~

~~64-906 Battery installations~~

~~Batteries installed as part of energy storage systems that are not self contained shall meet the requirements of Rule 64-800 to 64-814.~~

~~64-908 Facilities with energy storage systems~~

~~1) Any structure or building with an energy storage system shall have a conspicuous, legible, and permanent marking or directory installed on the exterior of the building or structure at a location acceptable to the Electrical Safety Authority.~~

~~2) The plaque or directory required by Subrule 1) shall indicate the location of system disconnecting means and that the structure contains energy storage systems.~~

Proposal Number: 2021-OA-007

Rule 68-072

Description of Change: Clarify existing Ontario Amendment to reflect ESA direction published on bulletin 68-7-14 (October 2019)

Submitted by: Electrical Safety Authority

Background:

This proposed change intends to address some confusion as terminology in Rule 68-072 appears contradictory as it requires a disconnect means within sight of the equipment and then permitted it behind a barrier which was then not within sight.

Rationale

The main intent of this 2018 Ontario Amendment was to allow access to disconnecting means for an outdoor pool, hot tub or spa without requiring access to the inside of a building. This is primarily an issue for service technicians and homeowners at dwellings. ESA published clarification to this requirement in bulletin 68-7-14 item 8 back in October 2019. The proposed wording change clarifies this intent to align with the intent.

Proposed Change:

Modify current Ontario Amendment to Rule 68-072

Add Rule 68-072 as follows:

68-072 Maintenance disconnecting means *for pool pumps, spas, and hot tubs* (see Appendix B)

A disconnecting means rated to interrupt the connected load shall be *provided for a pool pump, spa, and hot tub, and shall be*

a) readily accessible;

b) *within sight of its equipment located outdoors when the equipment is located outside of a dwelling; and*

c) *located not closer than 1.5 m from the inside walls of the pool, spa, or hot tub unless behind a permanent barrier that will prevent the occupant of the pool, spa, or hot tub from contacting the device; and*

d) *lockable capable of being locked in the open position when not within sight of its the equipment*

Proposal Number: 2021-OA-008

Rule 72-114

Description of Change: Delete existing Ontario Amendment 72-114 and associated Appendix B note

Submitted by: Electrical Safety Authority

Background & Rationale:

Rule 72-114 of OESC 2018 along with its associated Appendix B note have been added as new Rule 72-112 in CE Code 2021. These additions adopt the wording and figures from the respective parts in the OESC and the amendments listed above are no longer required.

Proposed Change:

Delete Rule 72-114

72-114 Location of receptacle on recreational vehicle lots (see Appendix B)

1) When a receptacle is provided for

a) back-in lots, the receptacle shall be located on the left (road) side of the parked vehicle, on a line that is 1.5 m to 2.1 m from the left edge (driver's side of the parked RV) of the stand and shall be located at any point on this line from the rear of the stand to 4.5 m forward of the rear of the stand;

b) drive-in lots, the receptacle shall be located on the left (road) side of the parked vehicle, on a line that is 1.5 m to 2.1 m from the left edge (driver's side of the parked RV) of the stand and shall be located at any point on this line from the front of the stand to 4.5 m back of the front of the stand; or

c) pull-through lots, the receptacle shall be located at any point along the line that is 1.5 m to 2.1 m from the left edge (driver's side of the parked RV) of the stand and shall be located at any point on this line between 4.9 m from the rear of the stand to the centre point between the two roads that give access to and egress from the pull-through lots.

2) The receptacle shall be located not less than 600 mm or more than 2.0 m above the ground and shall have an unobstructed entrance or passageway.

Delete Appendix B note and Figures - Back In Lot, Drive In Lot, Pull Through Lot

Rule 72-114

The recreational vehicle lot may be a back-in, drive-in, or pull-through type. The intent of Subrule 1) is to specify the location of the lot receptacle in order to harmonize with CSA Z240.6-2/C22.2 No. 148 requirements for power supply point of entry. For pull-through lots designed to accommodate vehicles towing boats or other trailers, the left edge (driver's side of the parked RV) of the stand should be marked in order to reduce the use of extension cords.

Proposal Number: 2021-OA-009

Rule 75-000

Description of Change: Amend current Ontario Amendment to Rule 75-000 to include central metering systems

Submitted by: Section 75 Committee

Background:

Existing Rule 75-902 contains requirements only for pole mounted central metering systems. There are some supply authority's now installing pad mounted central metering systems.

Rationale:

Added new subrule c) since central metering systems can be either pole mounted or padmounted. There has been an increased number of underground customer owned primary installations to an embedded supply authority's pad mounted transformer. There are no rules in the OESC that will permit the central metering system to be supplied from a pad mounted transformer.

Proposed Change:

75-000 Scope

1) This Section applies to

a) installations of primary and secondary lines except for lines owned by a supply authority;
~~and~~

b) poles and pole-mounted electrical equipment;~~and~~

c) central metering systems

2) This Section supplements or amends the general requirements of this Code.

Proposal Number: 2021-OA-010

Rule 75-002

Description of Change: Amend current Ontario Amendment to Rule 75-002 to include new definitions and Appendix B note

Submitted by: Section 75 Committee

Background:

Definitions added to provide clarity to common industry terms

Rationale:

Added definition for CMS. Previous definition only indicated what the acronym is but had no body to what defines a central metering system.

Added definition for demarcation point since other definitions references the demarcation point. Appendix B note added to clarify the supply authority defines the demarcation point.

Added embedded infrastructure to define electrical equipment owned by the supply authority.

Added definition for grades of construction since the term is used in the section.

Structure has been defined to clarify what objects would be considered a structure.

The OESC 28th Edition Proposals for Ontario Amendments

Proposed Change:

75-002 Special terminology (see Appendix B)

In this Section, the following definitions and abbreviations apply:

ACSR — aluminum conductor, steel reinforced

Classified — poles graded according to strength whereby the minimum circumferential dimensions are determined so that all poles of the same class, regardless of length, will withstand the same horizontal force applied in accordance with CAN/CSA-O15 for wood poles, CSA G40.21 for steel poles, CAN/CSA-A14 series for concrete poles, and ASCE Manual No. 104 for fibre-reinforced polymer.

CMS — central metering system—~~secondary system with one centralized meter~~ A metering system that is centrally located on the consumer side of the demarcation point to an embedded supply authority owned transformer, without a secondary breaker or switch, that te supplies any number of one or more consumer services on the same premise.

Demarcation point- the physical location where consumer owned electrical infrastructure interfaces interconnects with the supply authority's distribution system.

Distribution system — the system by which electrical power or energy is distributed to the receiving equipment; it includes components such as a primary line, a secondary line, services, distribution transformers, distribution equipment, and other equipment of a similar nature.

Embedded infrastructure: Any supply authority's owned electrical equipment installed on the consumers side of the demarcation point.

Free-standing pole — a pole structure and base assembly that is installed with engineering direction without the use of guys.

Grades of Construction- a classification of strength of structures, guys, crossarms, conductors, messengers, insulators, pins and fastenings based on relative hazards ranging from 1 through 3 with Grade 1 being the strongest.

Lines —

Primary line — a distribution system operating at more than 750 V but not more than 50 000 V phase-to-phase.

Secondary line — a distribution system operating at 750 V or less.

The OESC 28th Edition Proposals for Ontario Amendments

Neutral-supported cable — two or three insulated conductors and a bare neutral.

Open wire bus — a secondary line conductor that has a weatherproof covering on the phase conductors and that includes a bare neutral.

Pipelines — those items through which gases, liquids, or solids are conveyed, including pipe, components, and any appurtenances attached thereto, up to and including the isolating valves used at stations and other facilities.

Power conductor — a conductor that conveys electrical power or energy and is not part of a communication circuit.

Structure - Any object that can be placed, built, or erected composed of parts.

Appendix B

Rule 75-002 Demarcation point

The demarcation point is determined by the supply authority and is indicated in their conditions of service. This may also be known as the point of common coupling for the installations within the scope of Section 64.

Rule 75-002 Pipelines

A pipeline

- a) includes all associated branches, extensions, tanks, reservoirs, pumps, racks, compressors, loading facilities, and other outside works;
- b) does not include pipe-type electric power cables; and
- c) can be above-ground or underground.

Proposal Number: 2021-OA-011

Rule 75-200

Description of Change: Revised framing specifications

Submitted by: Section 75 Committee

Background:

Specifications revised as shown.

Rationale:

The following specifications were revised as editorial referencing the new Specification 35.1:

- 9.1
- 9.2
- 10.1
- 10.2
- 11.1
- 11.2
- 11.3
- 11.4
- 12.1
- 13.1
- 13.2
- 14.1
- 14.2
- 15.1
- 15.2
- 15.3
- 18.1
- 18.2
- 18.4

The following specification were revised to include reference to new Specification 35.1, editorial and/or removal of guying exemption for cables 1/0 AWG or smaller to align with other specification requirements since the pole framing are for dead end or angled applications:

The OESC 28th Edition Proposals for Ontario Amendments

- 10.3
- 10.4
- 10.5
- 12.2
- 12.3
- 13.3
- 13.4
- 14.3
- 14.4
- 16.2
- 17.4
- 18.3

The OESC 28th Edition Proposals for Ontario Amendments

Proposed Change:

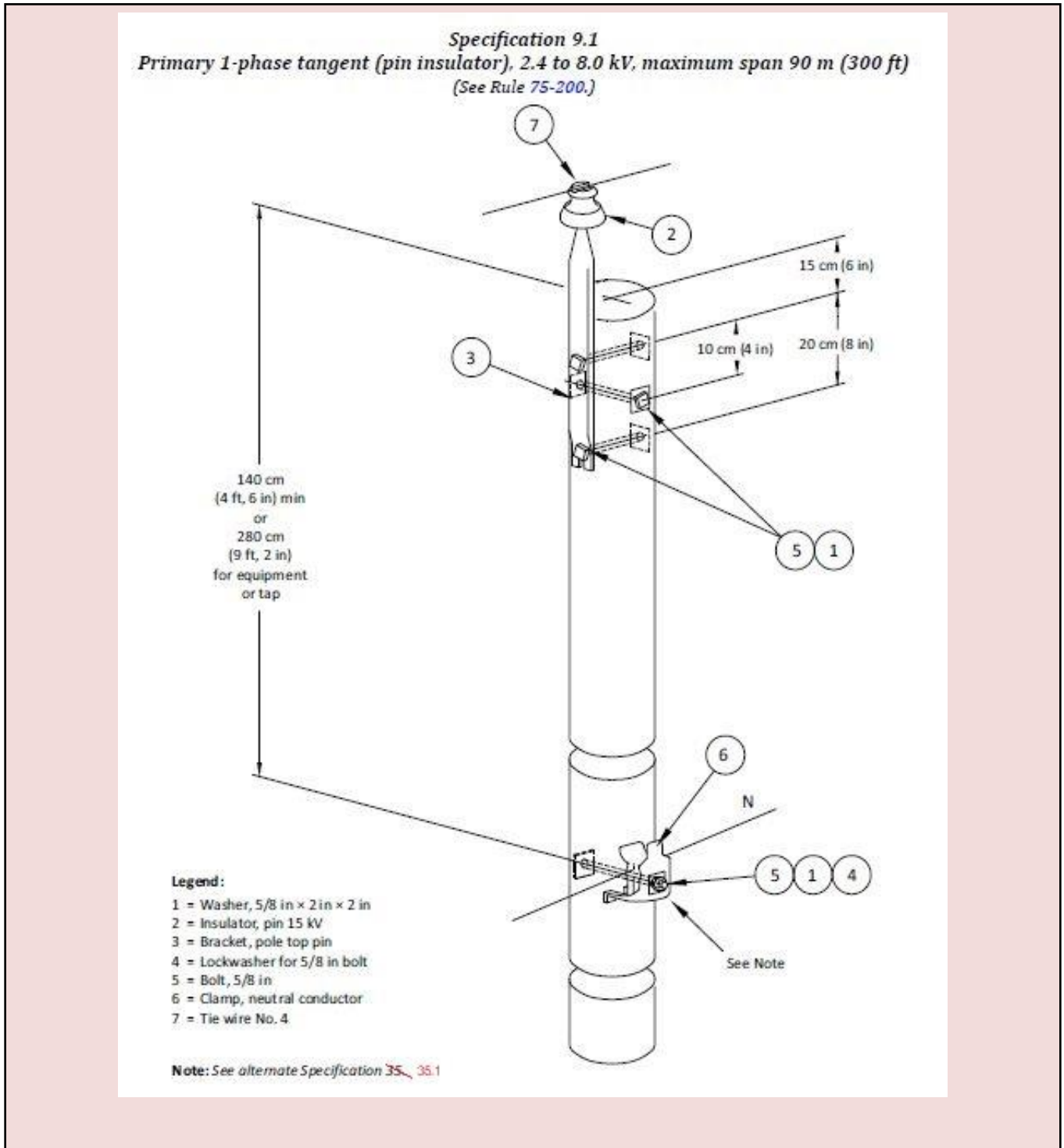

**The OESC 28th Edition
Proposals for Ontario Amendments**

Specification 9.2
Primary 1-phase line angle 4° to 15° (pin insulator),
2.4 to 8.0 kV, maximum span 90 m (300 ft)
(See Rule 75-200.)

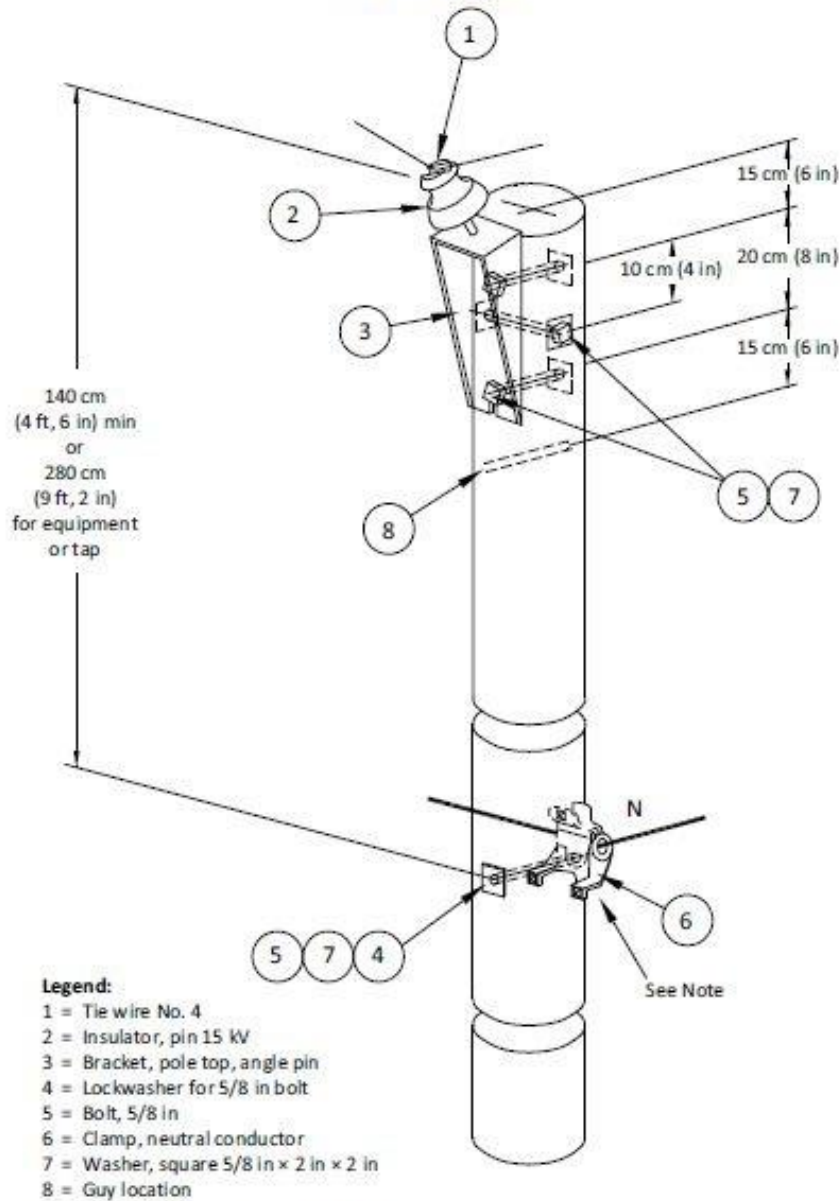

Note: See alternate Specification ~~35~~ 35.1

The OESC 28th Edition Proposals for Ontario Amendments

Specification 10.1
Primary 1-phase tangent (LP insulator), 2.4 to 16 kV, maximum span 90 m (300 ft)
(See Rule 75-200.)

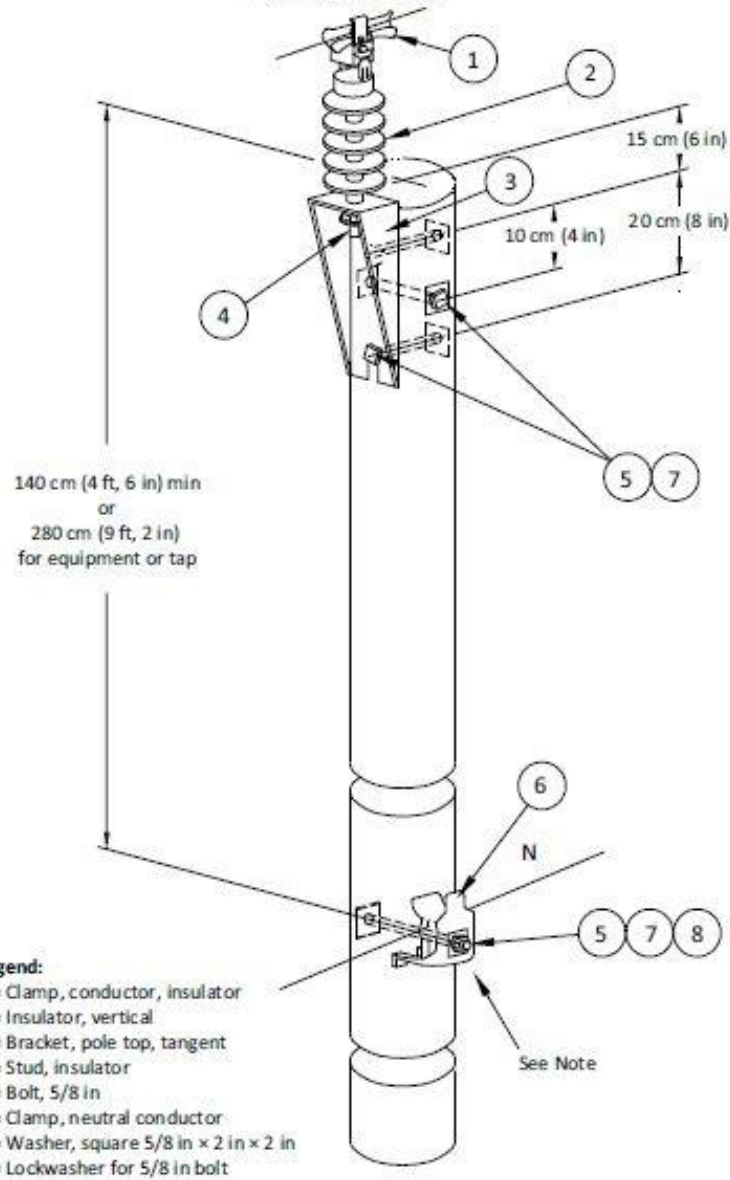

Note: See alternate Specification ~~35.1~~ 35.1

The OESC 28th Edition
Proposals for Ontario Amendments

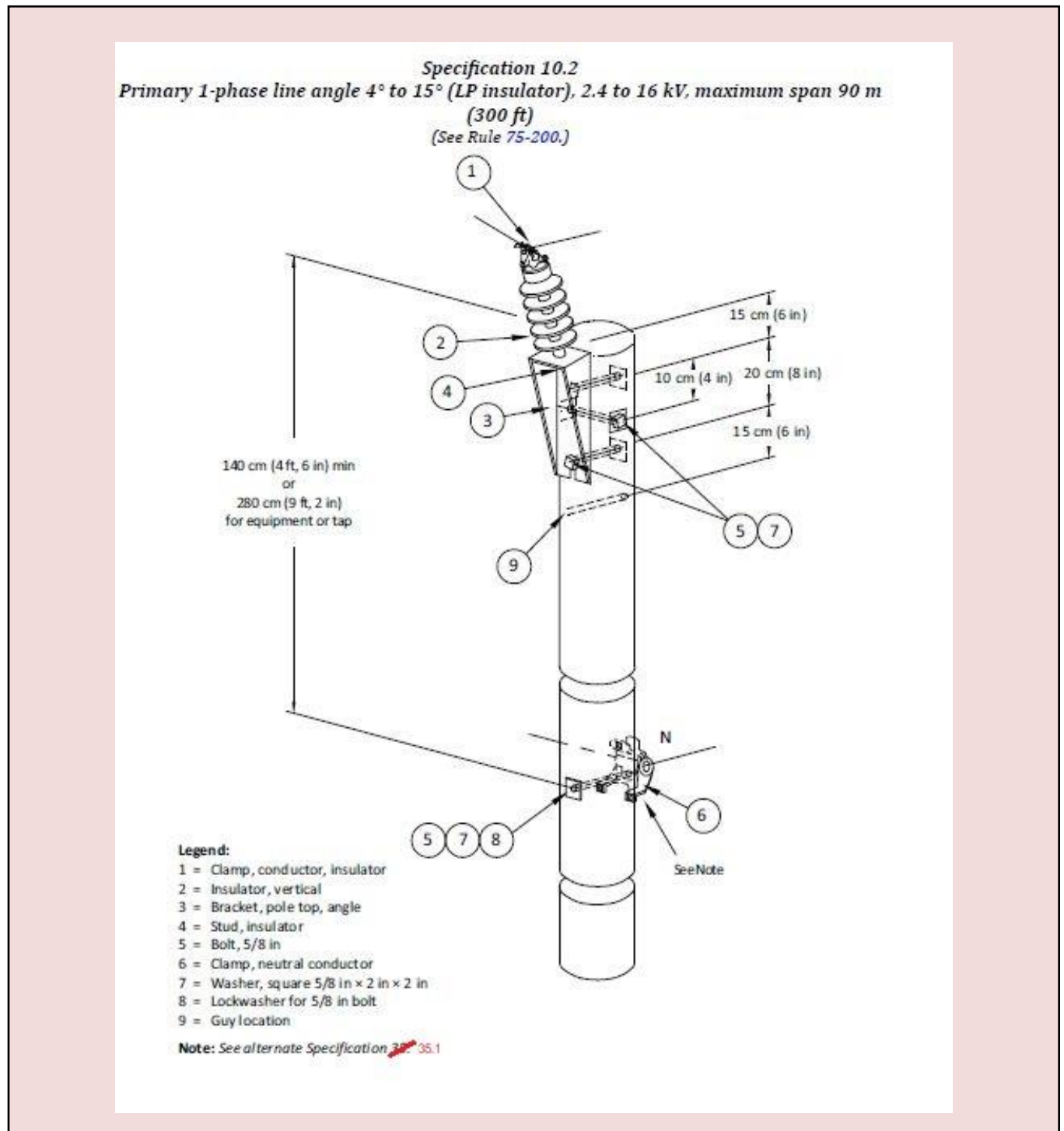

**The OESC 28th Edition
Proposals for Ontario Amendments**

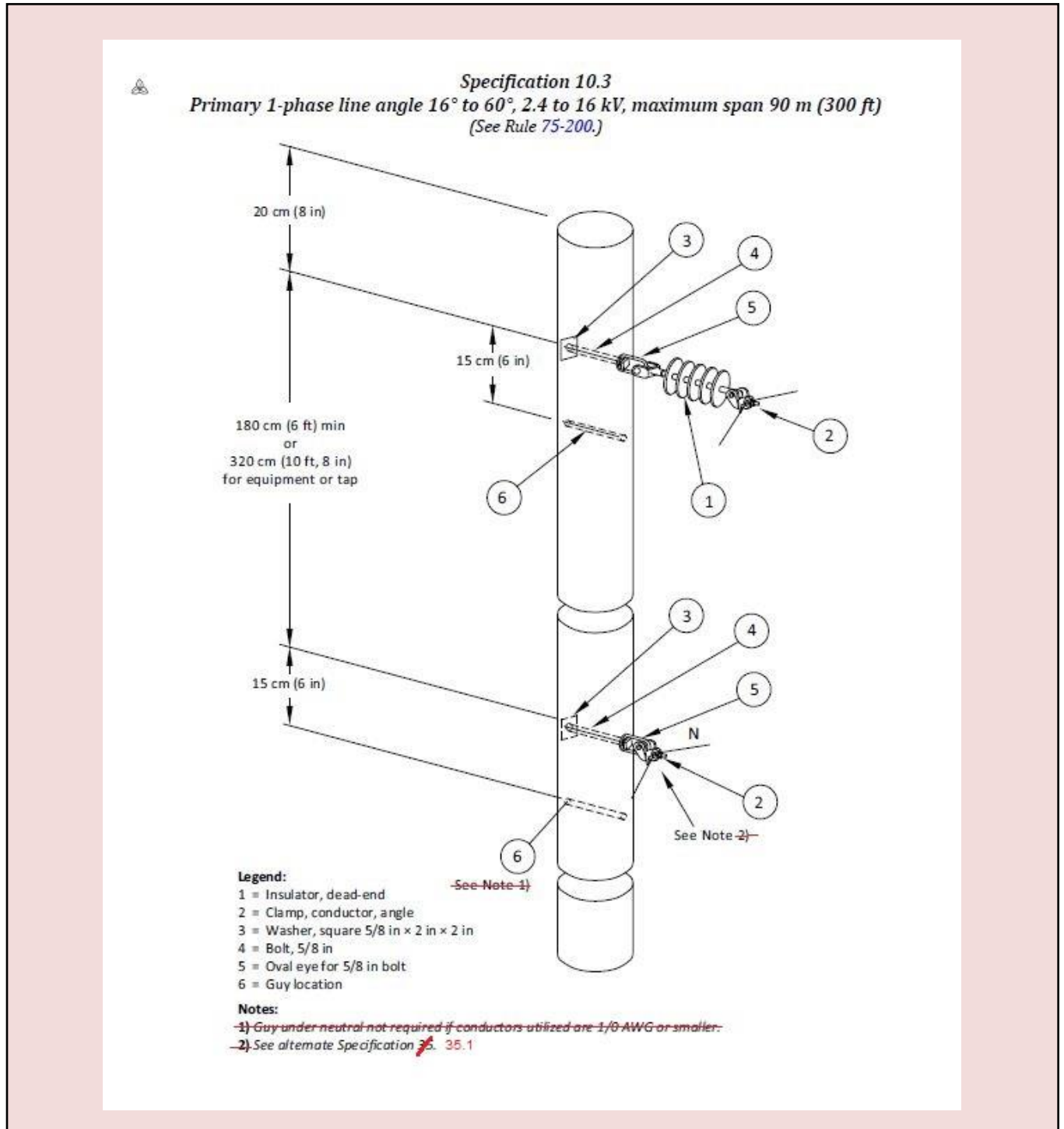

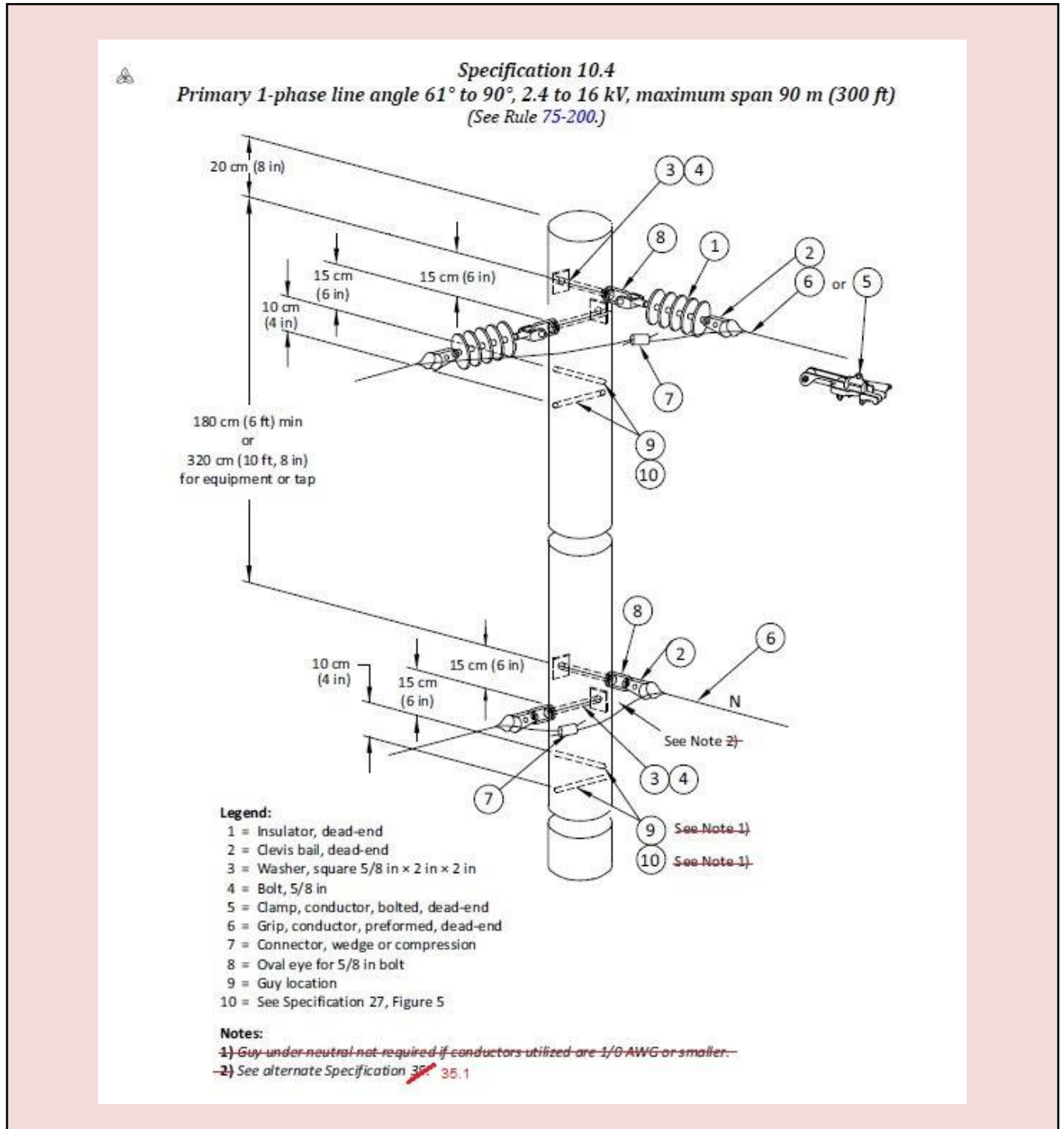

**The OESC 28th Edition
Proposals for Ontario Amendments**

Specification 10.5
Primary 1-phase dead-end, 2.4 to 16 kV, maximum span 90 m (300 ft)
(See Rule 75-200.)

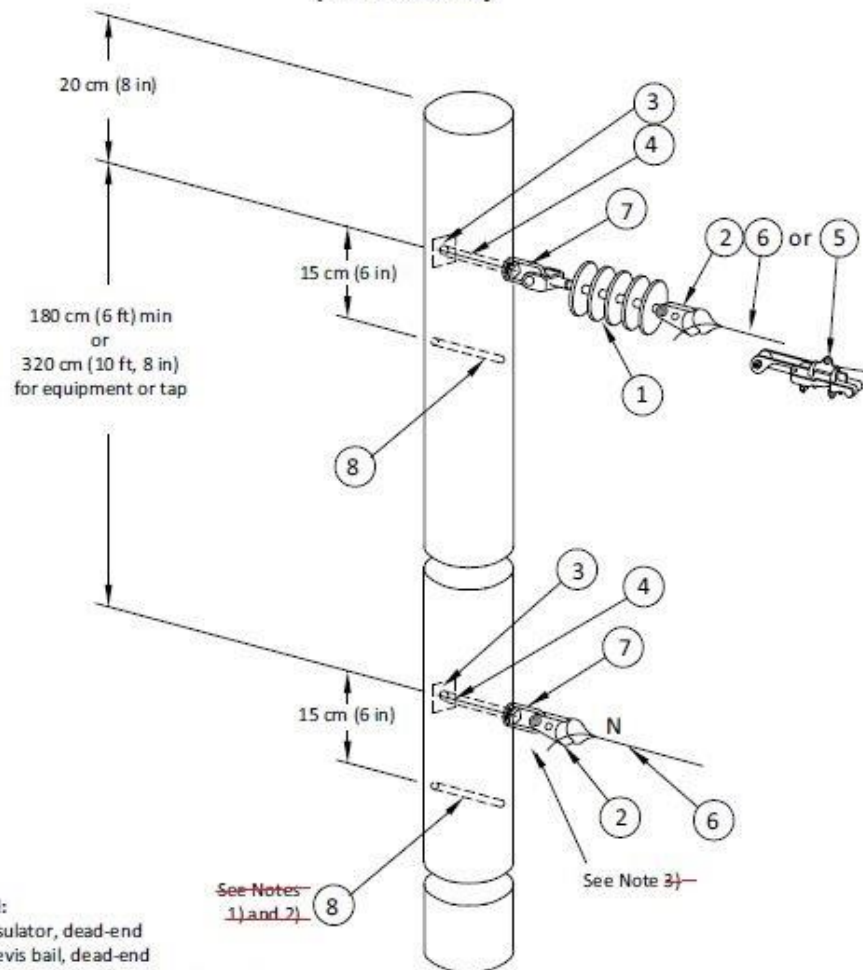

Legend:

- 1 = Insulator, dead-end
- 2 = Clevis bail, dead-end
- 3 = Washer, square 5/8 in x 2 in x 2 in
- 4 = Bolt, 5/8 in
- 5 = Clamp, conductor, bolted, dead-end
- 6 = Grip, conductor, preformed, dead-end
- 7 = Oval eye for 5/8 in bolt
- 8 = Guy location

Notes:

- ~~1) Guy under neutral not required if conductors utilized are 1/0 AWG or smaller.~~
- ~~2) Guy required if equipment installed on pole.~~
- ~~3) See alternate Specification ~~30~~ 35.1~~

The OESC 28th Edition
Proposals for Ontario Amendments

Specification 11.1
Primary 3-phase, underbuilt, line angle 4° to 15° crossarm (pin insulator), 2.4/4.16 to 8.0/13.8 kV, maximum span 60 m (200 ft)
(See Rule 75-200.)

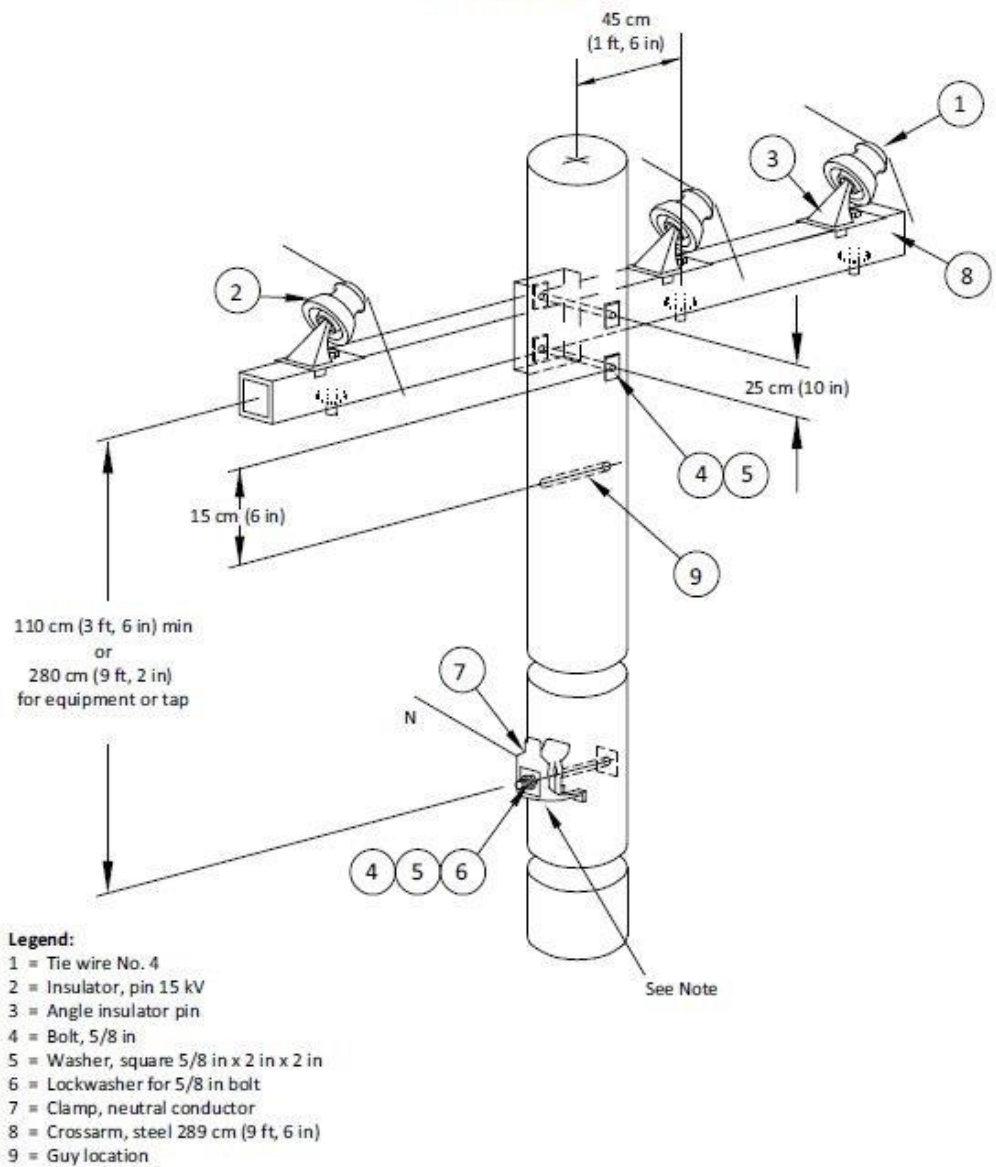

Note: See alternate Specification 35.1

**The OESC 28th Edition
Proposals for Ontario Amendments**

Specification 11.2
Primary 3-phase, line angle 4° to 15° crossarm (pin insulator), 2.4/4.16 to 8.0/13.8 kV
(See Rule 75-200.)

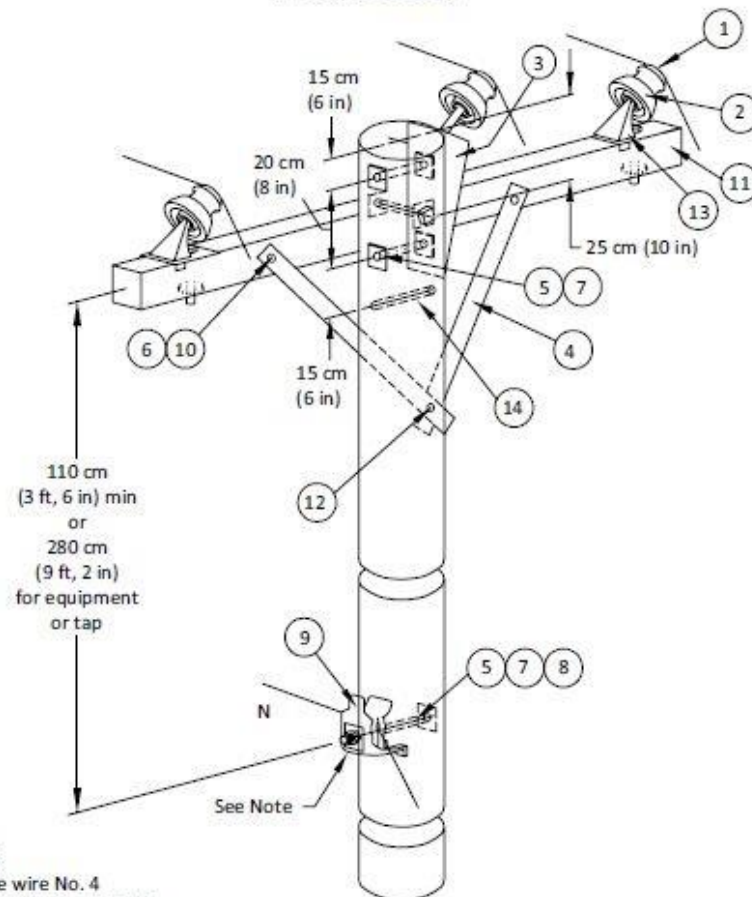

Legend:

- 1 = Tie wire No. 4
- 2 = Insulator, pin 15 kV
- 3 = Pole top angle pin
- 4 = Brace
- 5 = Bolt, 5/8 in
- 6 = Bolt, 3/8 in
- 7 = Washer, square 5/8 in x 2 in x 2 in
- 8 = Lockwasher for 5/8 in bolt
- 9 = Clamp, neutral conductor
- 10 = Washer, rd. 3/8 in
- 11 = Crossarm, wood (see span)
- 12 = Screw, lag 1/2 in x 4 1/2 in
- 13 = Angle insulator pin
- 14 = Guy location

For max. span	Crossarm
75 m (250 ft)	250 cm (8 ft, 4 in)
90 m (300 ft)	300 cm (9 ft, 10 in)

Note: See alternate Specification ~~38~~ 35.1

The OESC 28th Edition
Proposals for Ontario Amendments

Specification 11.3
Primary 3-phase, underbuilt tangent crossarm (pin insulator), 2.4/4.16 to 8.0/13.8 kV,
maximum span 60 m (200 ft)
(See Rule 75-200.)

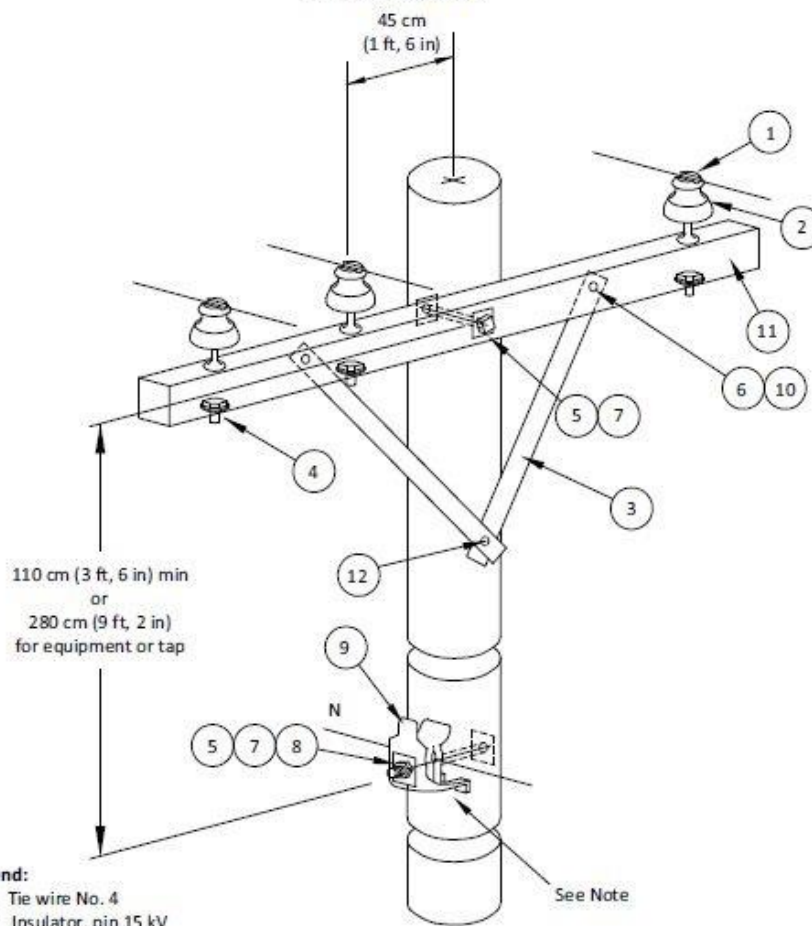

Legend:

- 1 = Tie wire No. 4
- 2 = Insulator, pin 15 kV
- 3 = Brace
- 4 = Steel insulator pin
- 5 = Bolt, 5/8 in
- 6 = Bolt, 3/8 in
- 7 = Washer, square 5/8 in x 2 in x 2 in
- 8 = Lockwasher for 5/8 in bolt
- 9 = Clamp, neutral conductor
- 10 = Washer, rd. 3/8 in
- 11 = Crossarm, wood, 300 cm (9 ft, 10 in)
- 12 = Screw, lag 1/2 in x 4-1/2 in

Note: See alternate Specification ~~35.1~~ 35.1

**The OESC 28th Edition
Proposals for Ontario Amendments**

Specification 11.4
Primary 3-phase, tangent, crossarm (pin insulator), 2.4/4.16 to 8.0/13.8 kV
(See Rule 75-200.)

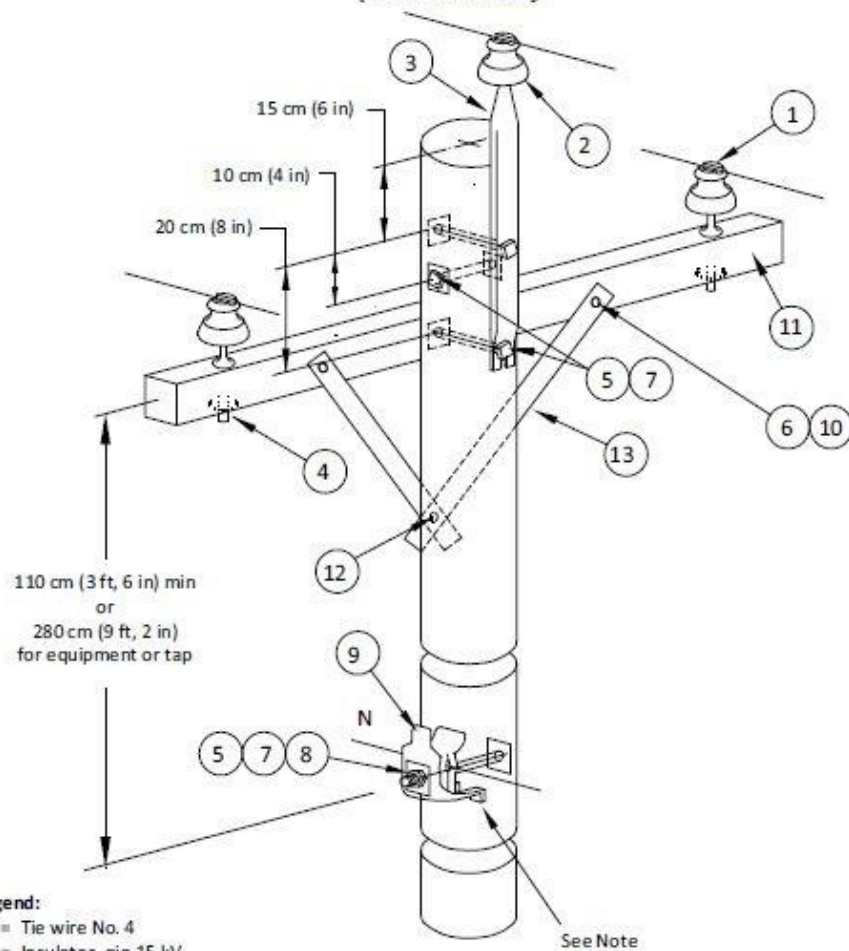

Legend:

- 1 = Tie wire No. 4
- 2 = Insulator, pin 15 kV
- 3 = Pole top pin
- 4 = Steel insulator pin
- 5 = Bolt, 5/8 in
- 6 = Bolt, 3/8 in
- 7 = Washer, square 5/8 in x 2 in x 2 in
- 8 = Lockwasher for 5/8 in bolt
- 9 = Clamp, neutral conductor
- 10 = Washer, rd. 3/8 in
- 11 = Crossarm, wood (see span)
- 12 = Screw, lag 1/2 in x 4-1/2 in
- 13 = Brace

Note: See alternate Specification ~~39~~ 35.1

For maximum span	Crossarm
75 m (250 ft)	250 cm (8 ft, 4 in) wood
90 m (300 ft)	300 cm (9 ft, 10 in) wood

**The OESC 28th Edition
Proposals for Ontario Amendments**

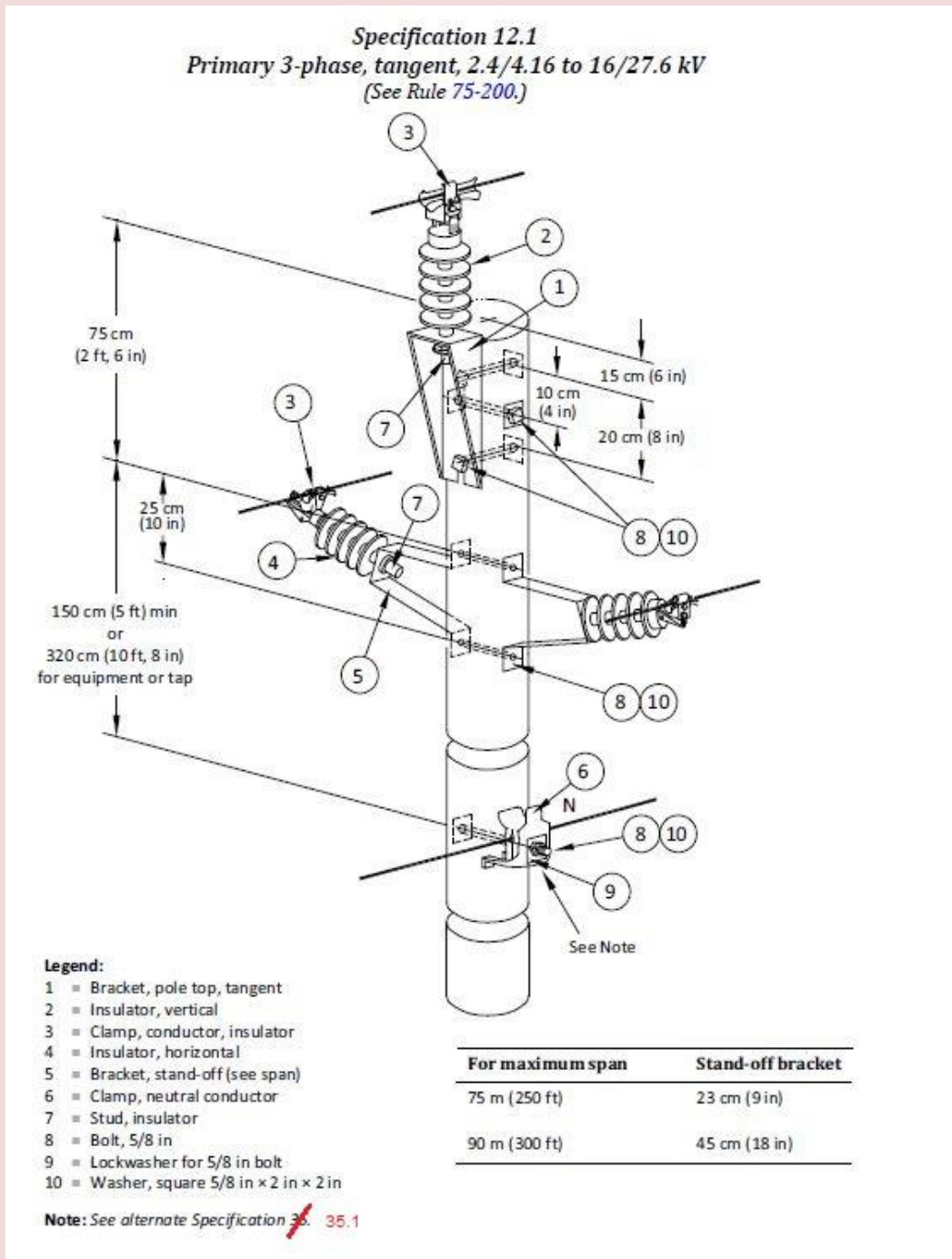

Specification 12.2
Primary 3-phase dead-end vertical, 2.4/4.16 to 16/27.6 kV
(See Rule 75-200.)

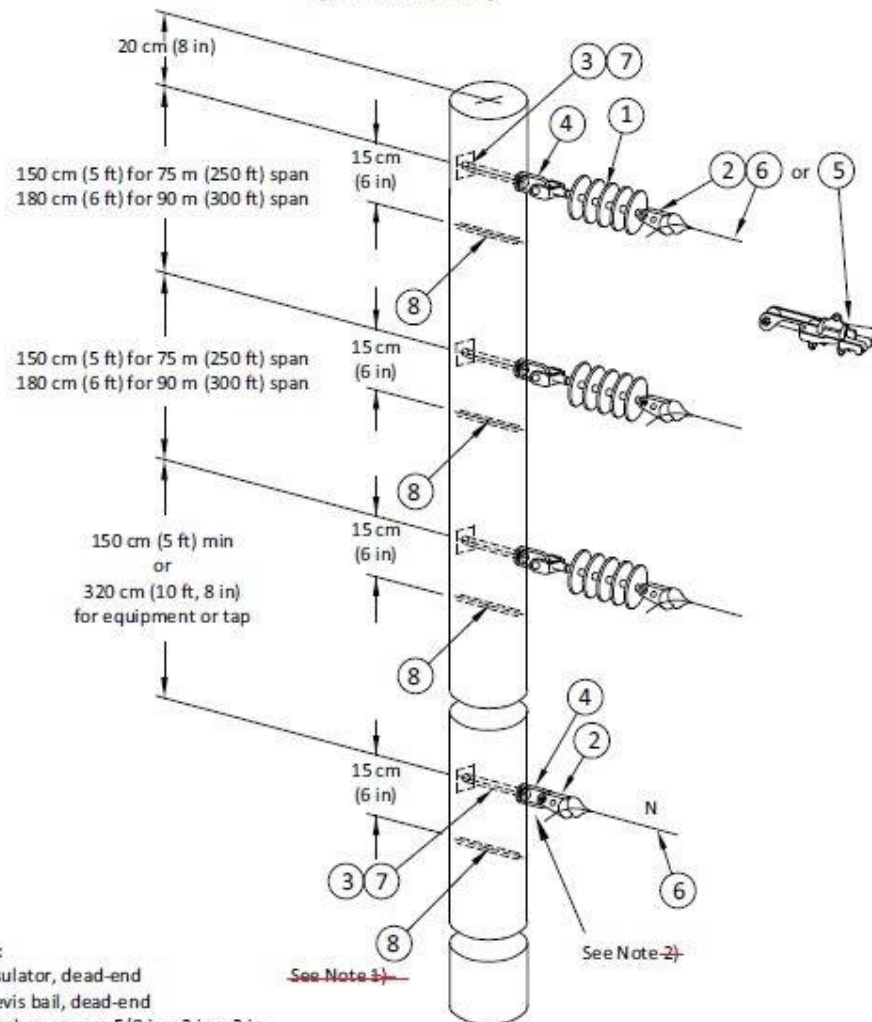

Legend:

- 1 = Insulator, dead-end
- 2 = Clevis bail, dead-end
- 3 = Washer, square 5/8 in x 2 in x 2 in
- 4 = Oval eye for 5/8 in bolt
- 5 = Clamp, conductor, bolted, dead-end
- 6 = Grip, conductor, preformed, dead-end
- 7 = Bolt, 5/8 in
- 8 = Guy location

Notes:

- 1) Guys under centre and bottom phases not required if conductors utilized are 1/0 AWG or smaller.
- 2) See alternate Specification 30. 35.1

**The OESC 28th Edition
Proposals for Ontario Amendments**

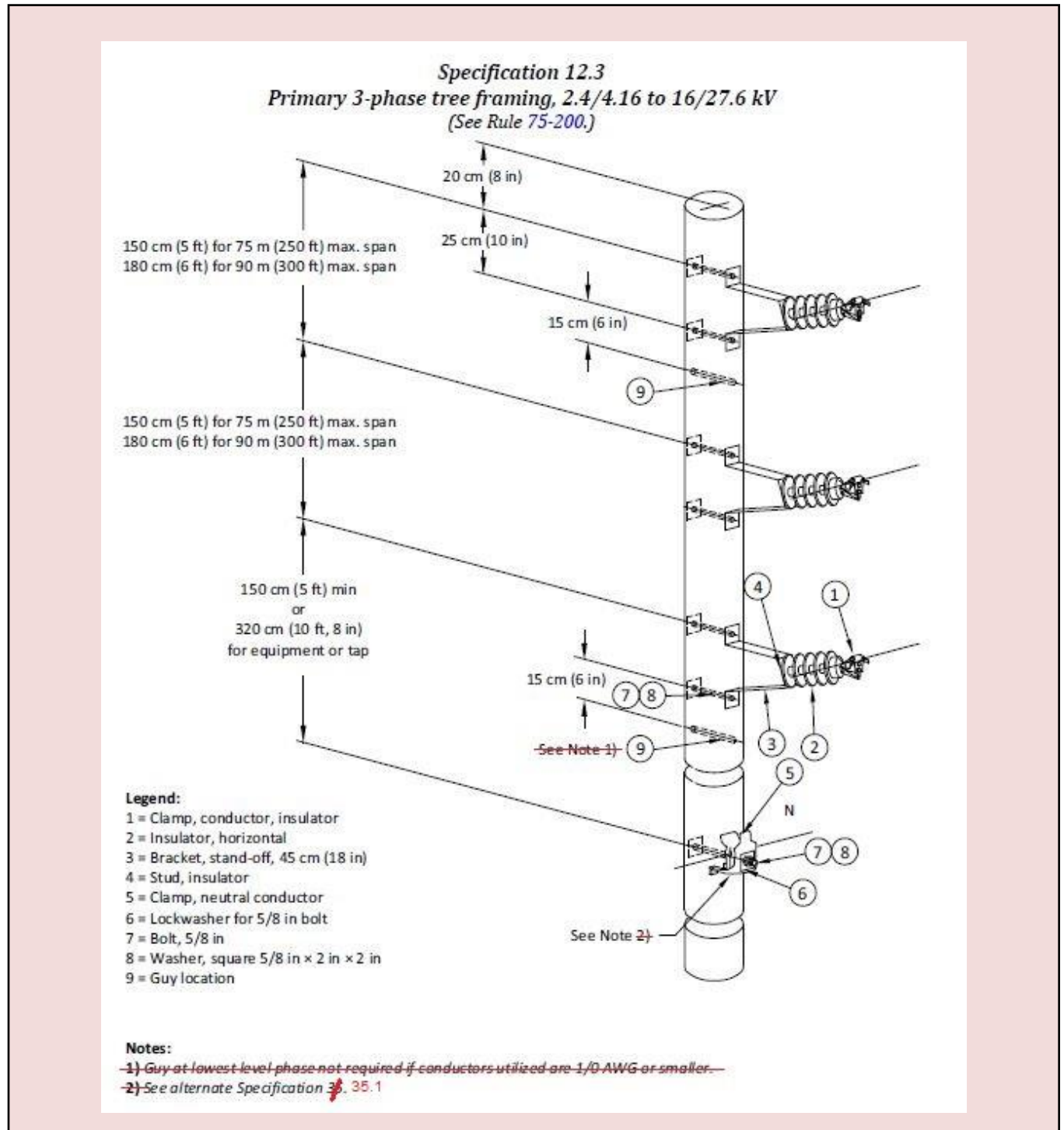

**The OESC 28th Edition
Proposals for Ontario Amendments**

Specification 13.1
Primary 3-phase line angle 4° to 15°, 2.4/4.16 to 16/27.6 kV
(See Rule 75-200.)

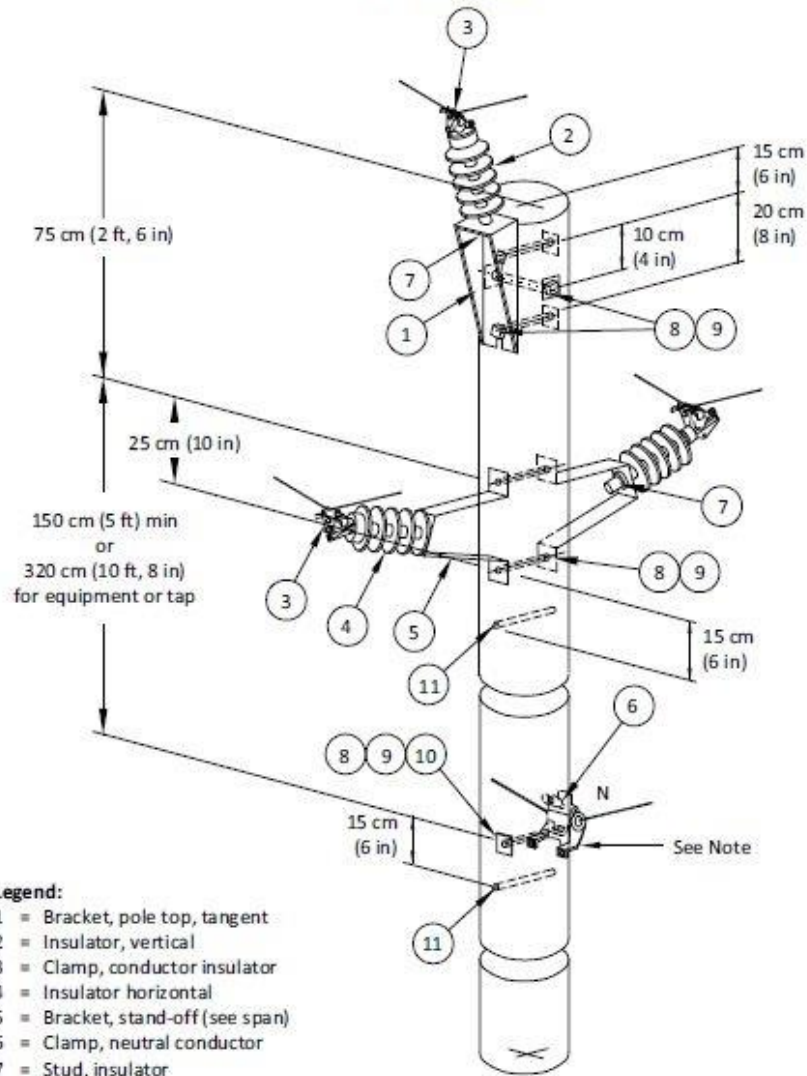

- Legend:**
- 1 = Bracket, pole top, tangent
 - 2 = Insulator, vertical
 - 3 = Clamp, conductor insulator
 - 4 = Insulator horizontal
 - 5 = Bracket, stand-off (see span)
 - 6 = Clamp, neutral conductor
 - 7 = Stud, insulator
 - 8 = Bolt, 5/8 in
 - 9 = Washer, square 5/8 in x 2 in x 2 in
 - 10 = Lockwasher for 5/8 in bolt
 - 11 = Guy location

For maximum span	Stand-off bracket
75 m (250 ft)	23 cm (9 in)
90 m (300 ft)	45 cm (18 in)

Note: See alternate Specification ~~35.1~~ 35.1

Specification 13.2
Primary 3-phase line angle 16° to 45°, 2.4/4.16 to 16/27.6 kV
(See Rule 75-200.)

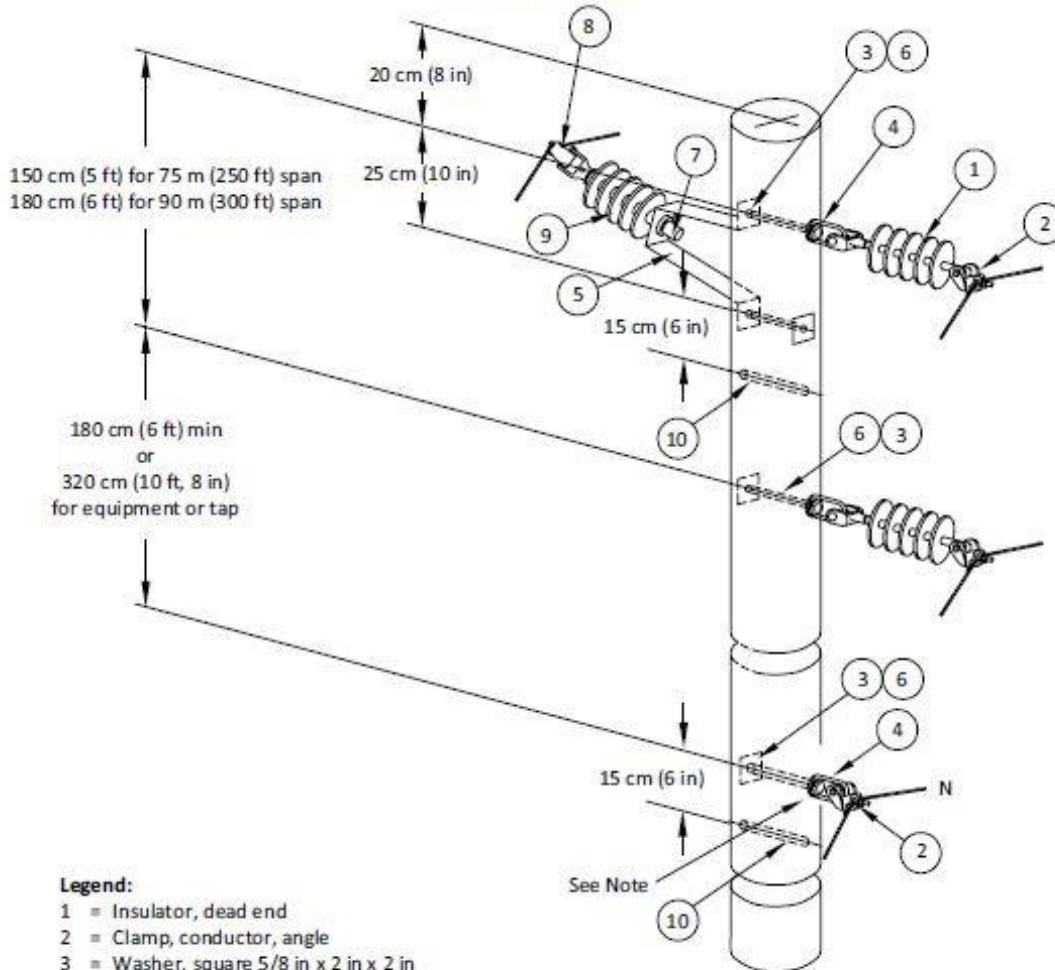

Legend:

- 1 = Insulator, dead end
- 2 = Clamp, conductor, angle
- 3 = Washer, square 5/8 in x 2 in x 2 in
- 4 = Oval eye for 5/8 in bolt
- 5 = Bracket, stand-off
- 6 = Bolt, 5/8 in
- 7 = Stud, insulator
- 8 = Clamp, conductor, insulator
- 9 = Insulator, vertical
- 10 = Guy location

Note: See alternate Specification ~~35.1~~ 35.1

For maximum span	Stand-off bracket
75 m (250 ft)	23 cm (9 in)
90 m (300 ft)	45 cm (18 in)

Specification 13.3
Primary 3-phase line angle 16° to 60°, 2.4/4.16 to 16/27.6 kV
(See Rule 75-200.)

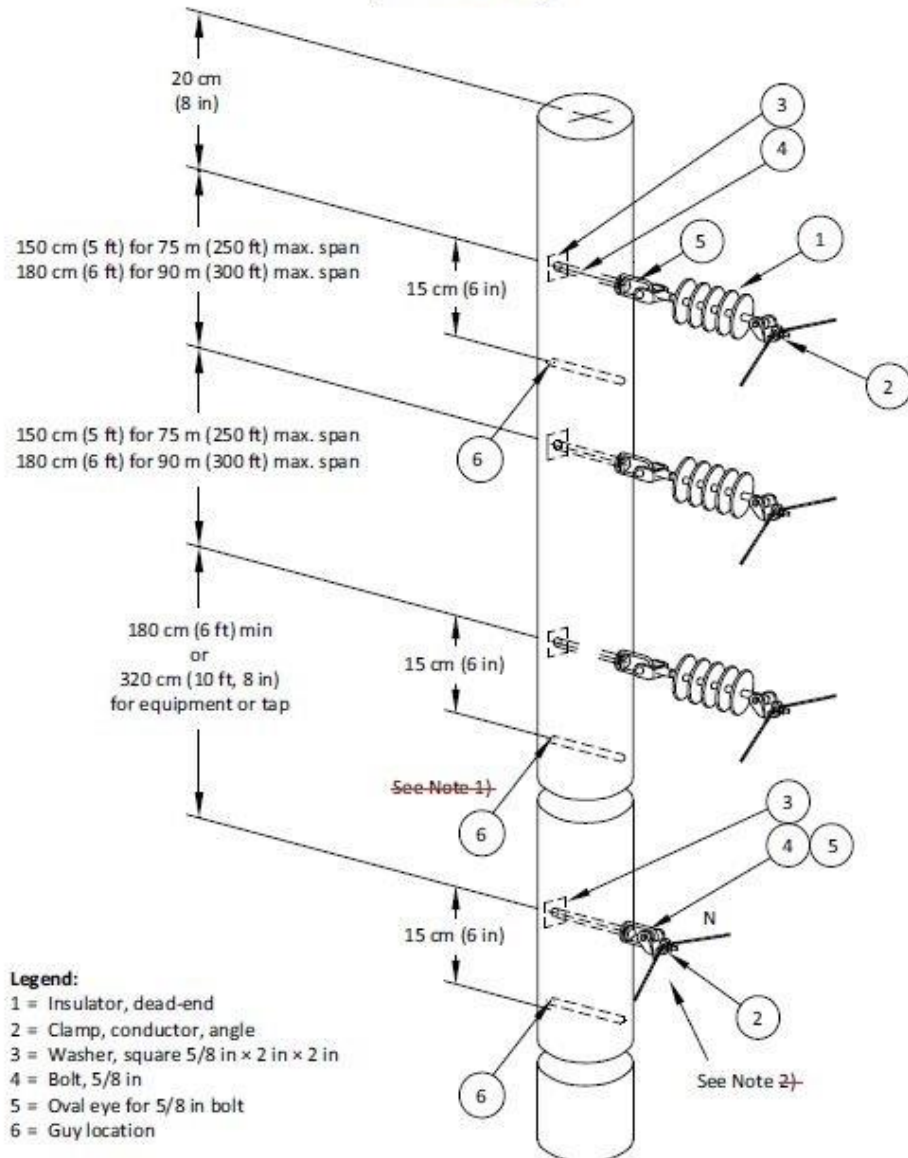

- Legend:**
- 1 = Insulator, dead-end
 - 2 = Clamp, conductor, angle
 - 3 = Washer, square 5/8 in x 2 in x 2 in
 - 4 = Bolt, 5/8 in
 - 5 = Oval eye for 5/8 in bolt
 - 6 = Guy location

- Notes:**
- ~~1) Guy under bottom phase not required if conductors utilized are 1/0 AWG or smaller.~~
 - ~~2) See alternate Specification 30.35.1~~

Specification 13.4
Primary 3-phase line angle 61° to 90°, 2.4/4.16 to 16/27.6 kV
(See Rule 75-200.)

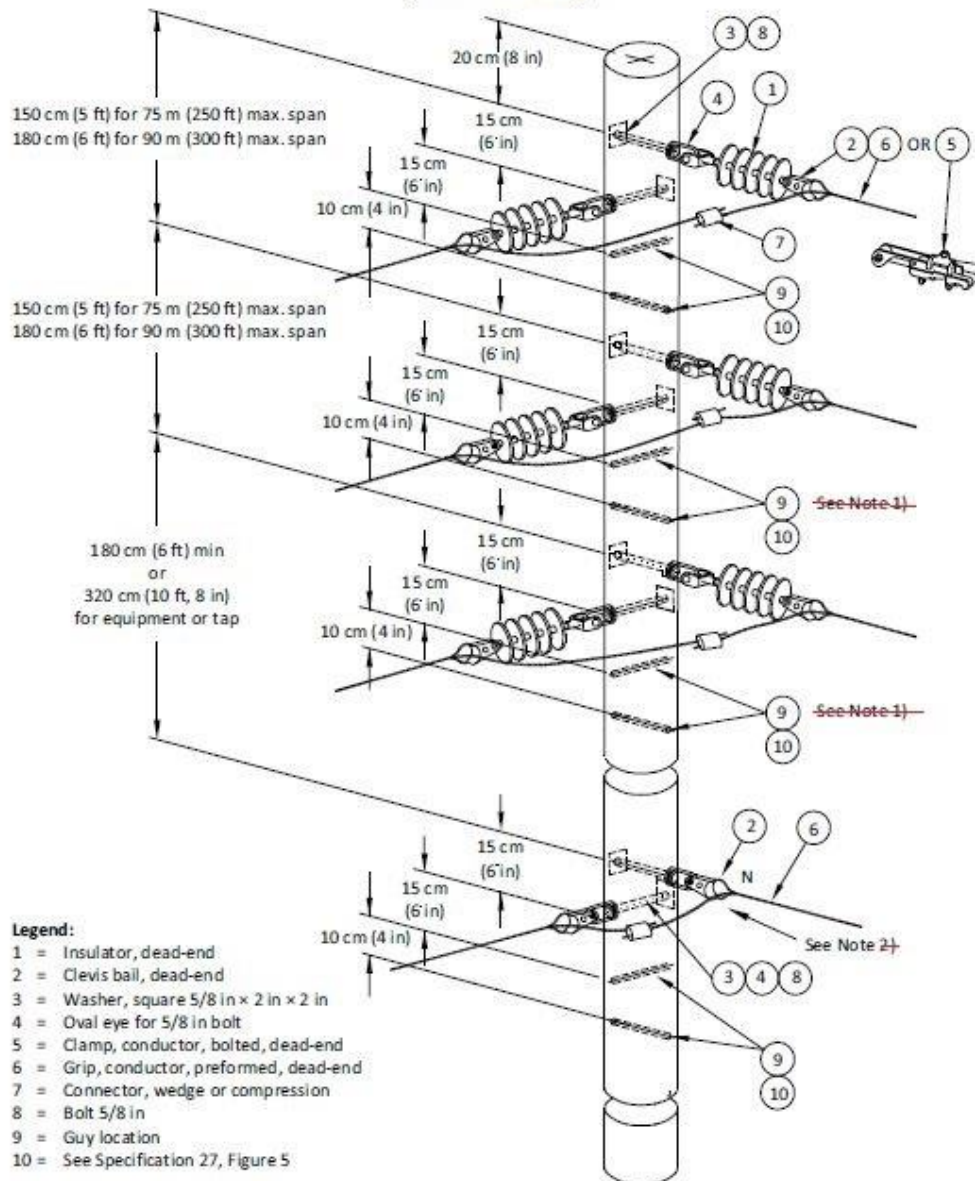

**The OESC 28th Edition
Proposals for Ontario Amendments**

Specification 14.1
Primary 3-phase, tangent, crossarm (LP insulator), 2.4/4.16 to 16/27.6 kV
(See Rule 75-200.)

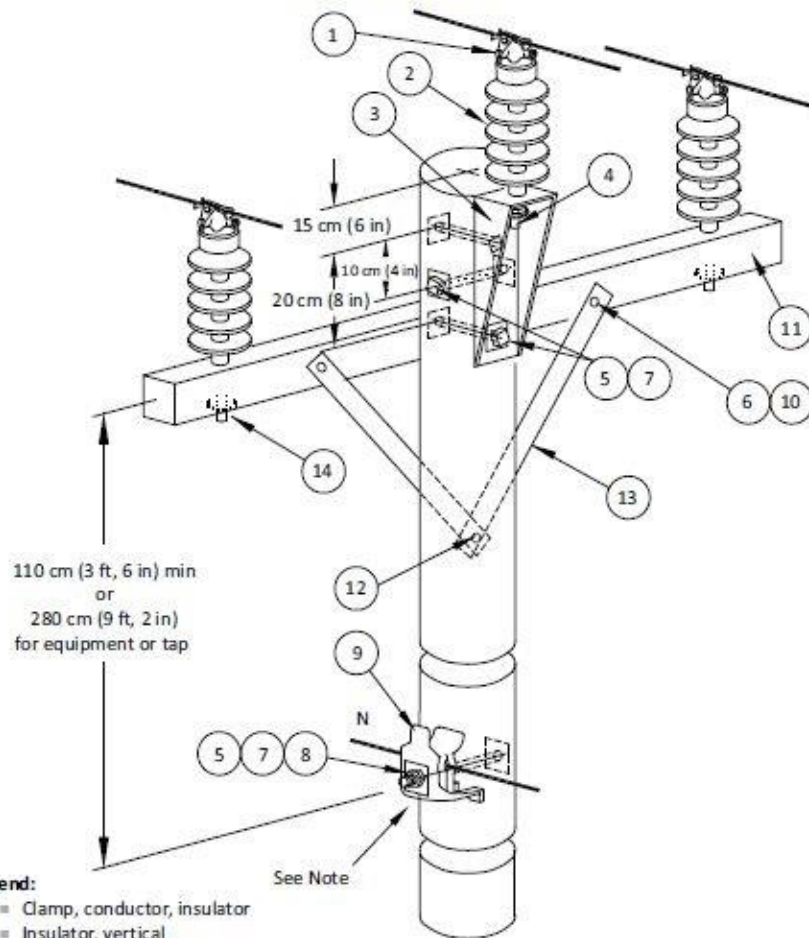

Legend:

- 1 = Clamp, conductor, insulator
- 2 = Insulator, vertical
- 3 = Bracket, pole top, tangent
- 4 = Stud insulator, 5/8 in x 3 in
- 5 = Bolt, 5/8 in
- 6 = Bolt, 3/8 in
- 7 = Washer, square 5/8 in x 2 in x 2 in
- 8 = Lockwasher for 5/8 in bolt
- 9 = Clamp, neutral conductor
- 10 = Washer, rd. 3/8 in
- 11 = Crossarm, wood (see span)
- 12 = Screw, lag 1/2 in x 4-1/2 in
- 13 = Brace
- 14 = Stud insulator, 5/8 in x 7 in

Note: See alternate Specification ~~35.35.1~~

For maximum span	Crossarm
75 m (250 ft)	250 cm (8 ft, 4 in)
90 m (300 ft)	300 cm (9 ft, 10 in)

**The OESC 28th Edition
Proposals for Ontario Amendments**

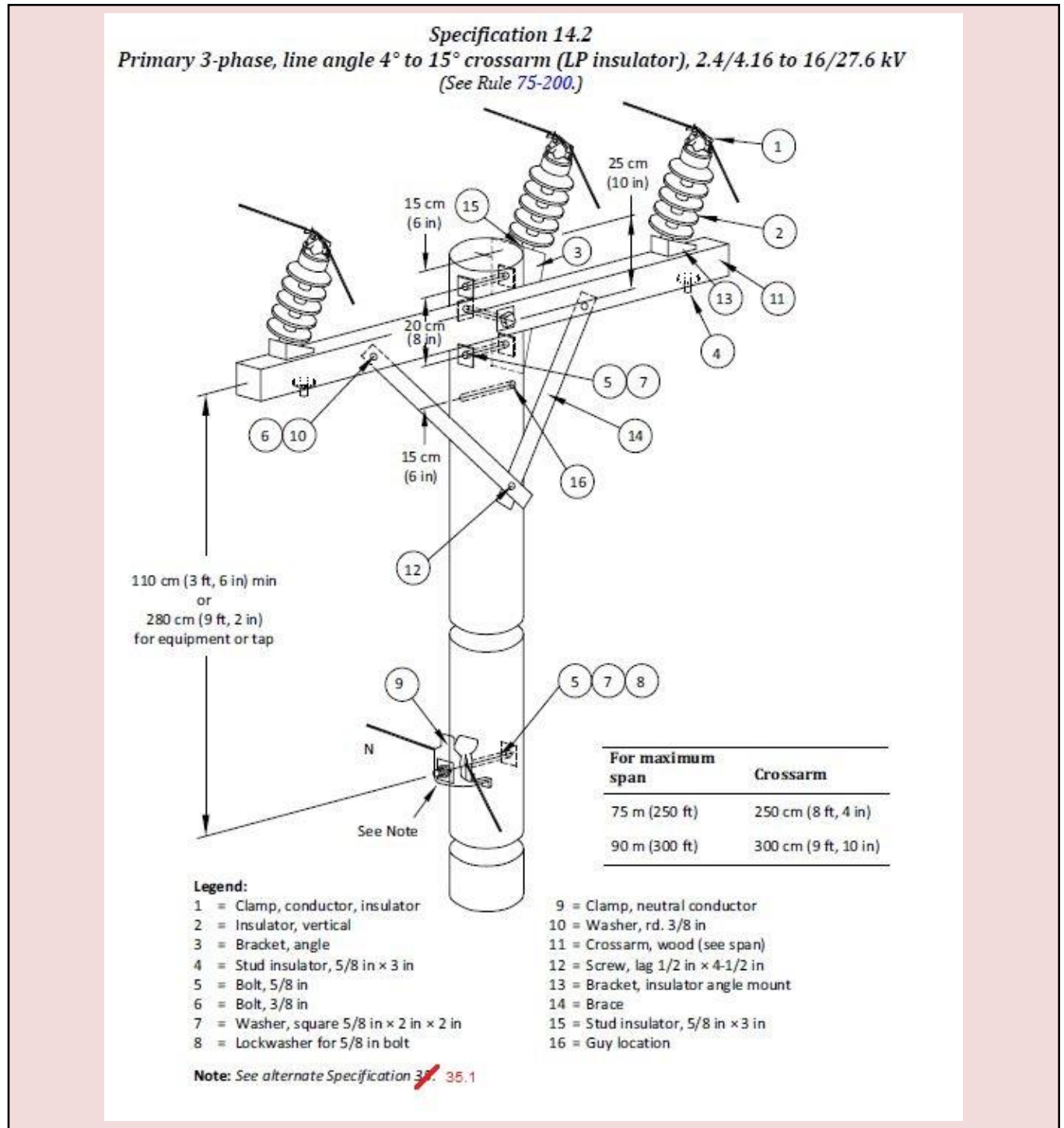

Specification 14.3
Primary 3-phase dead-end, crossarm (triangular), 2.4/4.16 to 16/27.6 kV
(See Rule 75-200.)

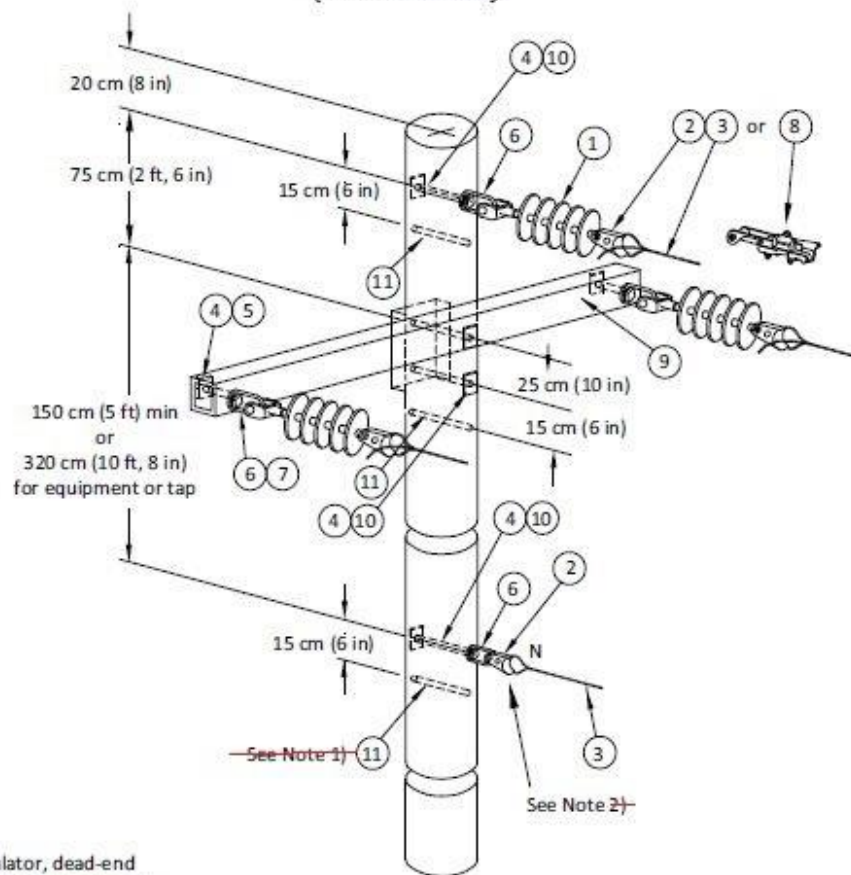

Legend:

- 1 = Insulator, dead-end
- 2 = Clevis bail, dead-end
- 3 = Grip, conductor, preformed, dead-end
- 4 = Washer, square 5/8 in x 2 in x 2 in
- 5 = Lockwasher for 5/8 in bolt
- 6 = Oval eye for 5/8 in bolt
- 7 = Bolt 5/8 in
- 8 = Clamp, conductor, bolted, dead-end
- 9 = Crossarm, steel (see span)
- 10 = Bolt, 5/8 in x 6 in
- 11 = Guy location

For maximum span

For maximum span	Crossarm
75 m (250 ft)	170 cm (5 ft, 6 in)
90 m (300 ft)	230 cm (7 ft, 6 in)

Notes:

- 1) ~~Guy under neutral not required if conductors utilized are 1/0 AWG or smaller.~~
- 2) ~~See alternate Specification 36. 35.1~~

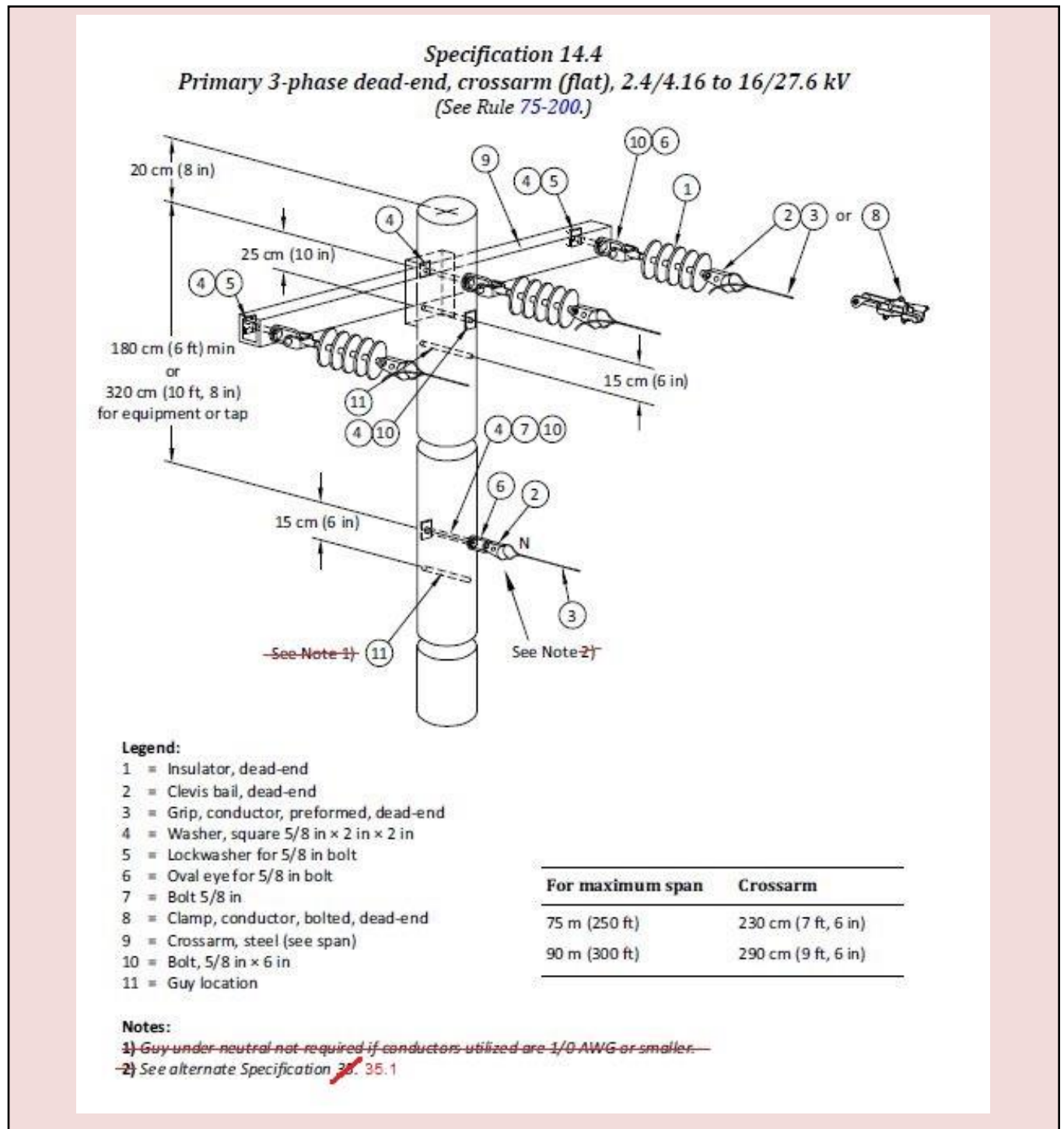

**The OESC 28th Edition
Proposals for Ontario Amendments**

Specification 15.1
Primary 3-phase, underbuilt, tangent or line angle 0° to 15°, 2.4/4.16 to 16/27.6 kV
(See Rule 75-200.)

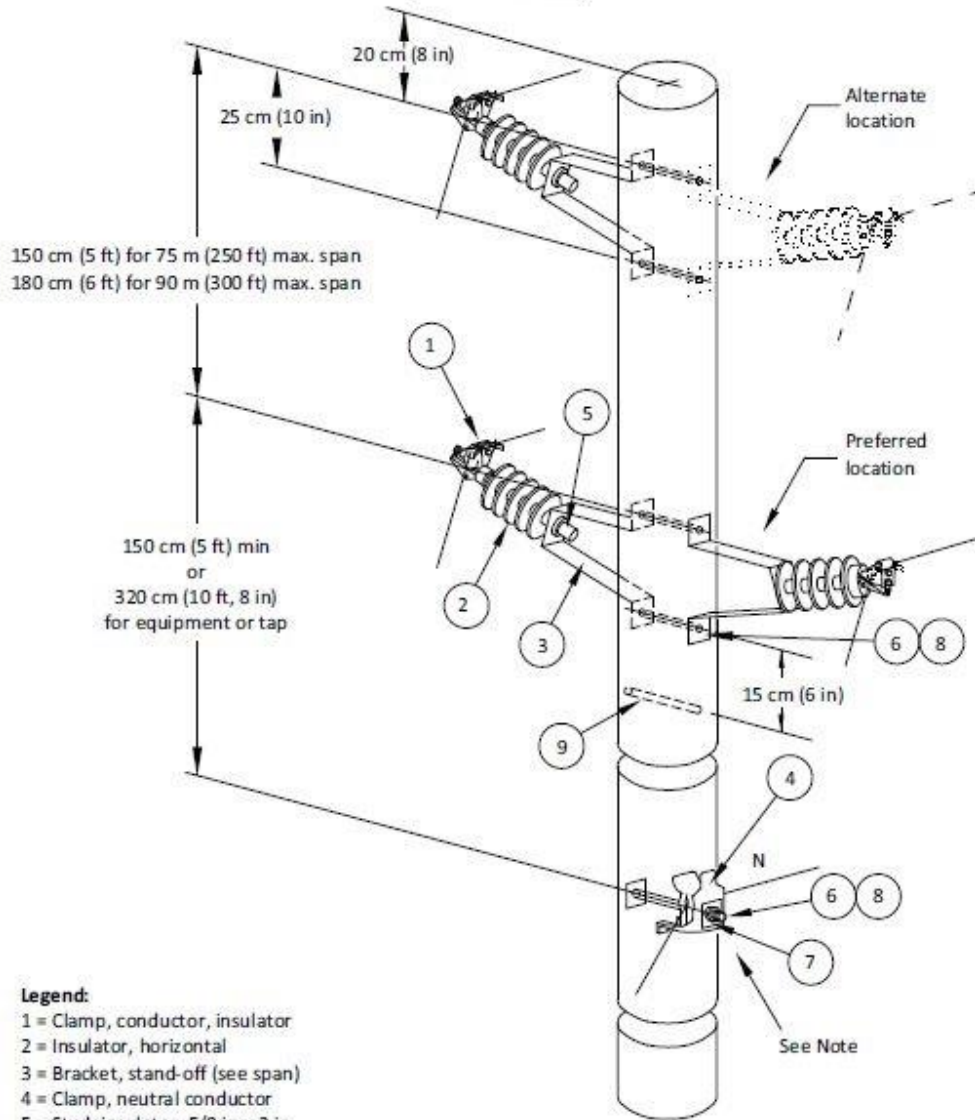

- Legend:**
- 1 = Clamp, conductor, insulator
 - 2 = Insulator, horizontal
 - 3 = Bracket, stand-off (see span)
 - 4 = Clamp, neutral conductor
 - 5 = Stud, insulator, 5/8 in x 3 in
 - 6 = Bolt, 5/8 in
 - 7 = Lockwasher, for 5/8 in bolt
 - 8 = Washer, square 5/8 in x 2 in x 2 in
 - 9 = Guy location

Note: See alternate Specification ~~35~~ 35.1

For maximum span	Stand-off bracket
75 m (250 ft)	23 cm (9 in)
90 m (300 ft)	45 cm (18 in)

**The OESC 28th Edition
Proposals for Ontario Amendments**

Specification 15.2
Primary 3-phase, underbuilt, tangent crossarm (LP insulator), 2.4/4.16 to 16/27.6 kV,
maximum span 60 m (200 ft)
(See Rule 75-200.)

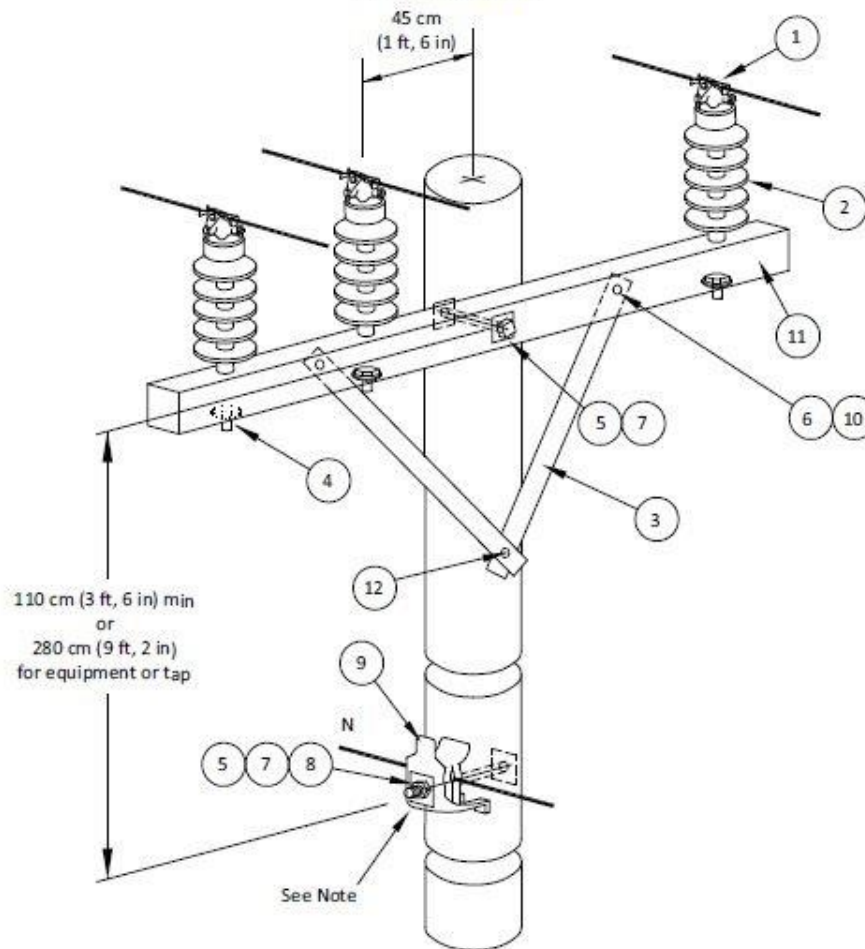

Legend:

- | | |
|------------------------------------|---|
| 1 = Clamp, conductor, insulator | 7 = Washer, square 5/8 in × 2 in × 2 in |
| 2 = Insulator, vertical | 8 = Lockwasher for 5/8 in bolt |
| 3 = Brace | 9 = Clamp, neutral conductor |
| 4 = Stud, insulator, 5/8 in × 7 in | 10 = Washer, rd. 3/8 in |
| 5 = Bolt, 5/8 in | 11 = Crossarm, wood, 300 cm (9 ft, 10 in) |
| 6 = Bolt, 3/8 in | 12 = Screw, lag 1/2 in × 4-1/2 in |

Note: See alternate Specification [35.1](#)

The OESC 28th Edition
Proposals for Ontario Amendments

Specification 15.3
Primary 3-phase, underbuilt, line angle 4° to 15° crossarm (LP insulator), 2.4/4.16 to 16/27.6 kV, maximum span 60 m (200 ft)
(See Rule 75-200.)

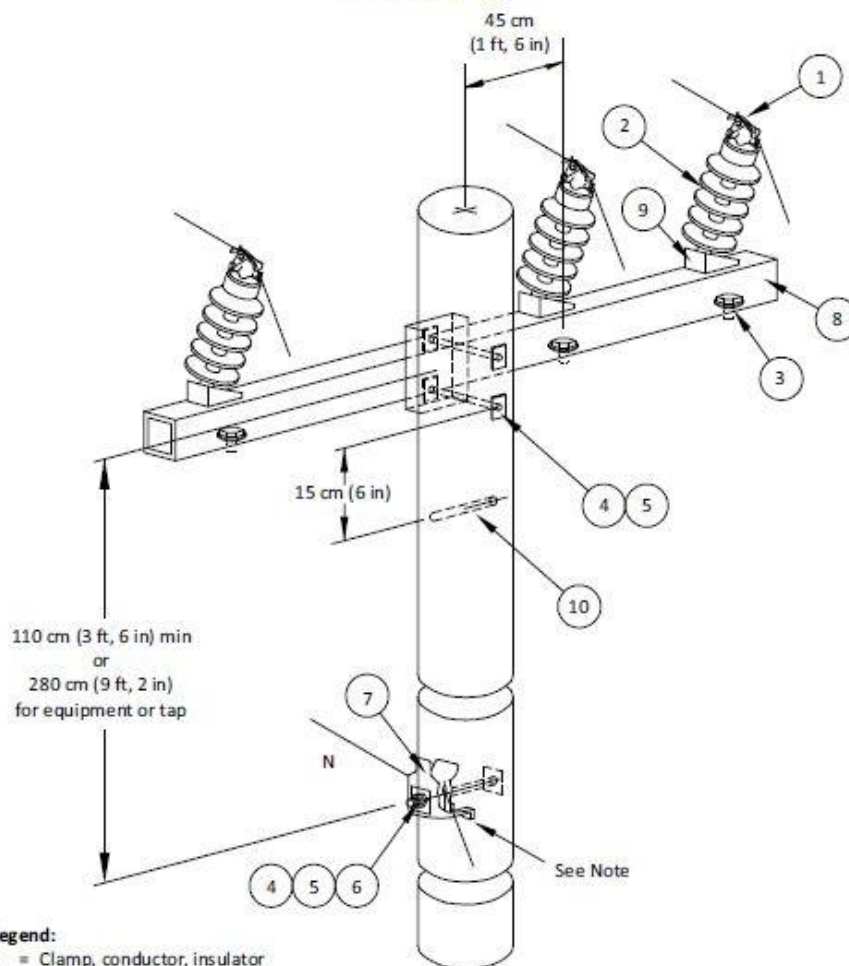

Legend:

- 1 = Clamp, conductor, insulator
- 2 = Insulator, vertical
- 3 = Stud, insulator
- 4 = Bolt, 5/8 in
- 5 = Washer, square 5/8 in × 2 in × 2 in
- 6 = Lockwasher for 5/8 in bolt
- 7 = Clamp, neutral conductor
- 8 = Crossarm, steel 290 cm (9 ft, 6 in)
- 9 = Bracket, insulator angle mount
- 10 = Guy location

Note: See alternate Specification ~~35.1~~ 35.1

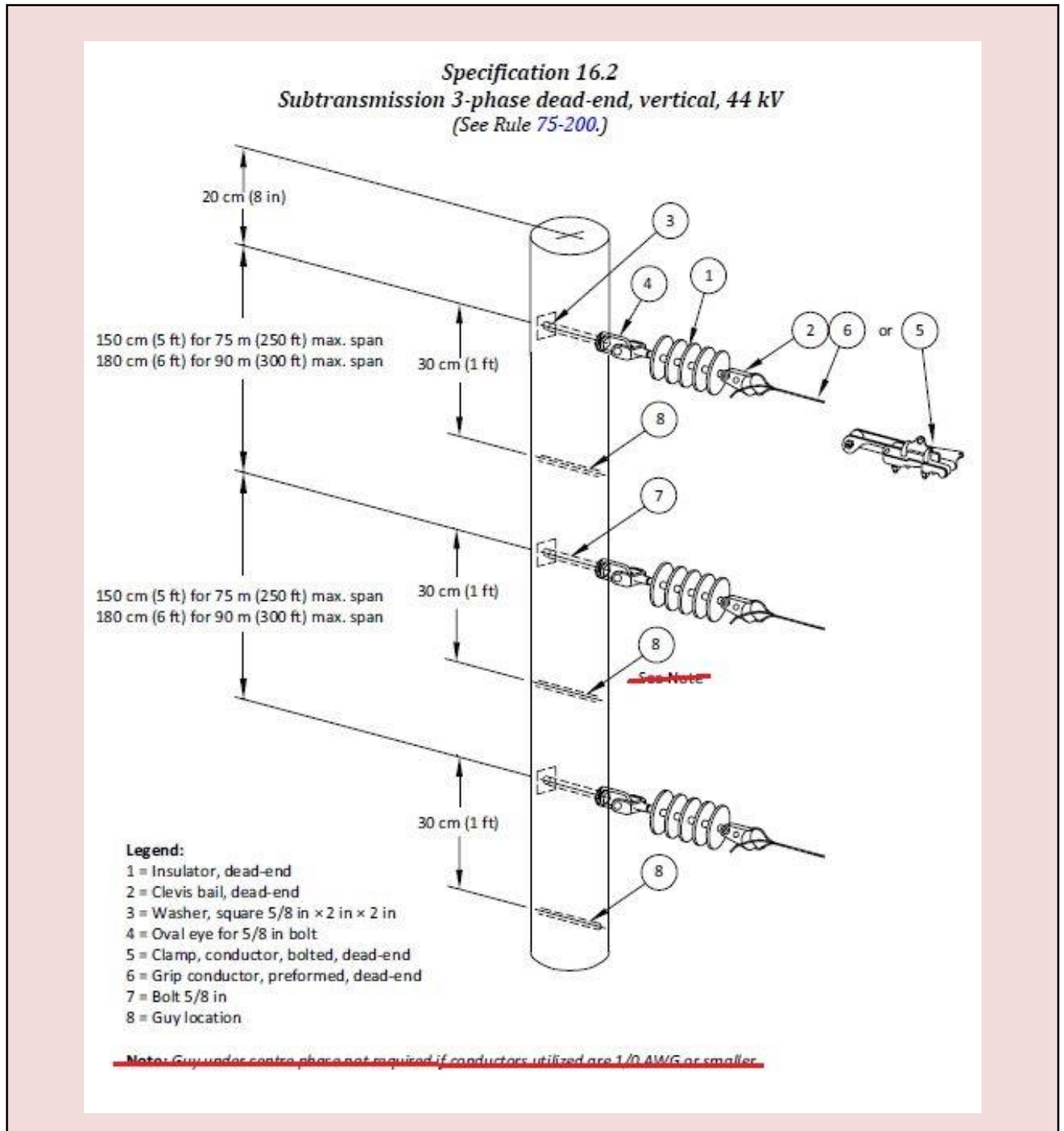

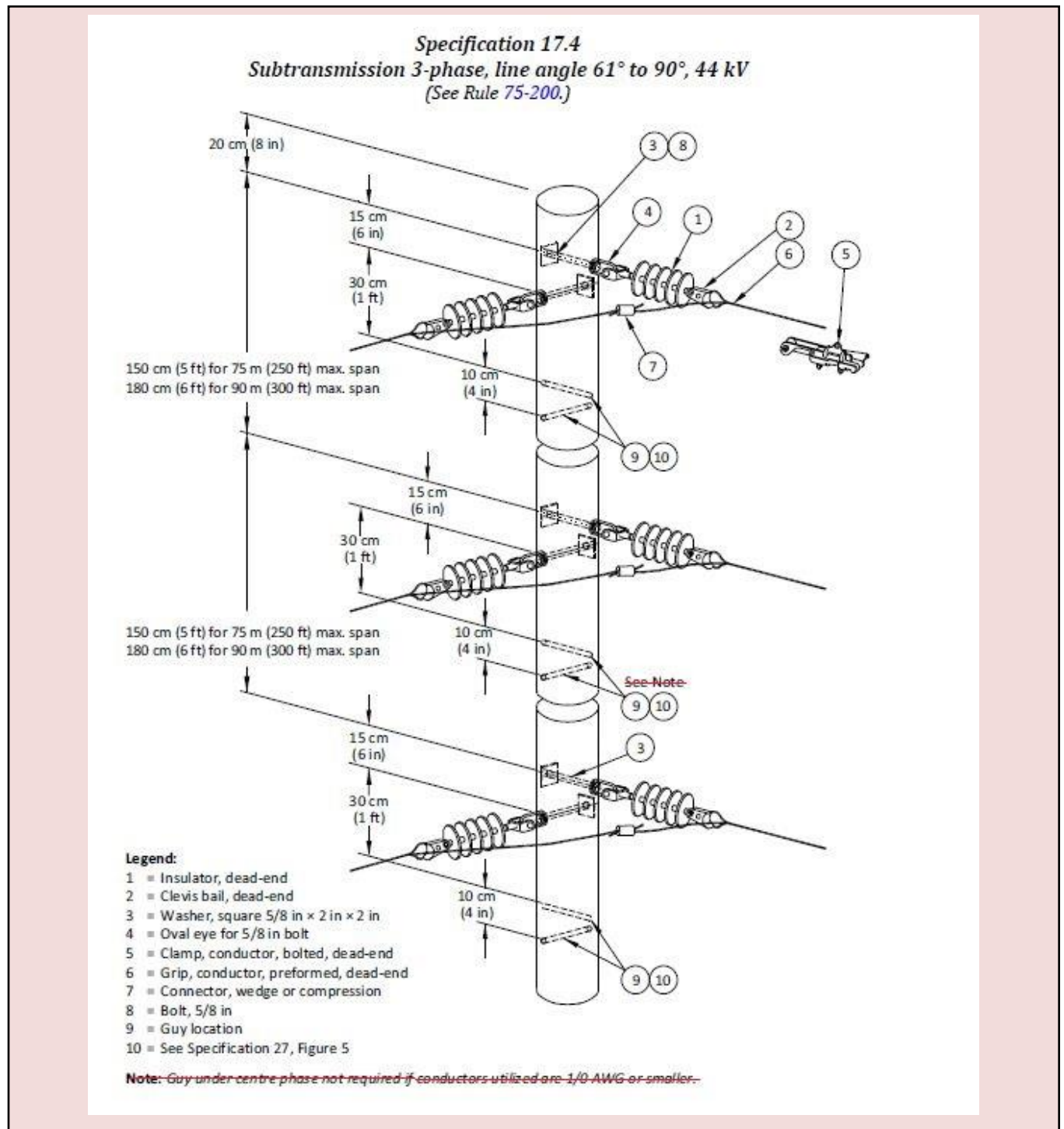

**The OESC 28th Edition
Proposals for Ontario Amendments**

Subtransmission

Specification 18.1

Primary 3-phase tangent, crossarm, 44 kV, maximum span 90 m (300 ft)
(See Rule 75-200.)

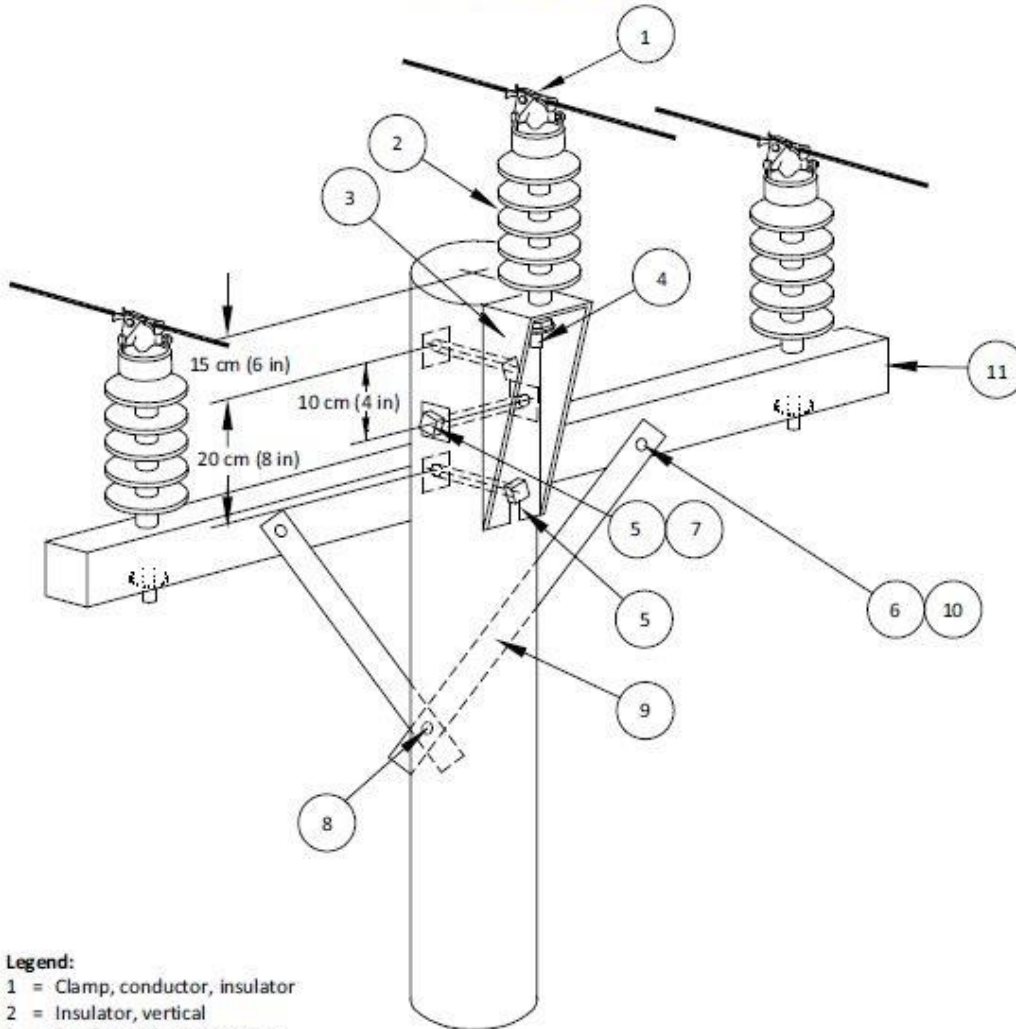

Legend:

- 1 = Clamp, conductor, insulator
- 2 = Insulator, vertical
- 3 = Bracket, pole top, tangent
- 4 = Stud, insulator
- 5 = Bolt, 5/8 in
- 6 = Bolt, 3/8 in
- 7 = Washer, square 5/8 in x 2 in x 2 in
- 8 = Screw, lag 1/2 in x 4-1/2 in
- 9 = Brace
- 10 = Washer, rd. 3/8 in
- 11 = Crossarm, wood 300 cm (9 ft, 10 in)

**The OESC 28th Edition
Proposals for Ontario Amendments**

Subtransmission *Specification 18.2*
Primary 3-phase, line angle 4° to 15°, crossarm, 44 kV, maximum span 90 m (300 ft)
 (See Rule 75-200.)

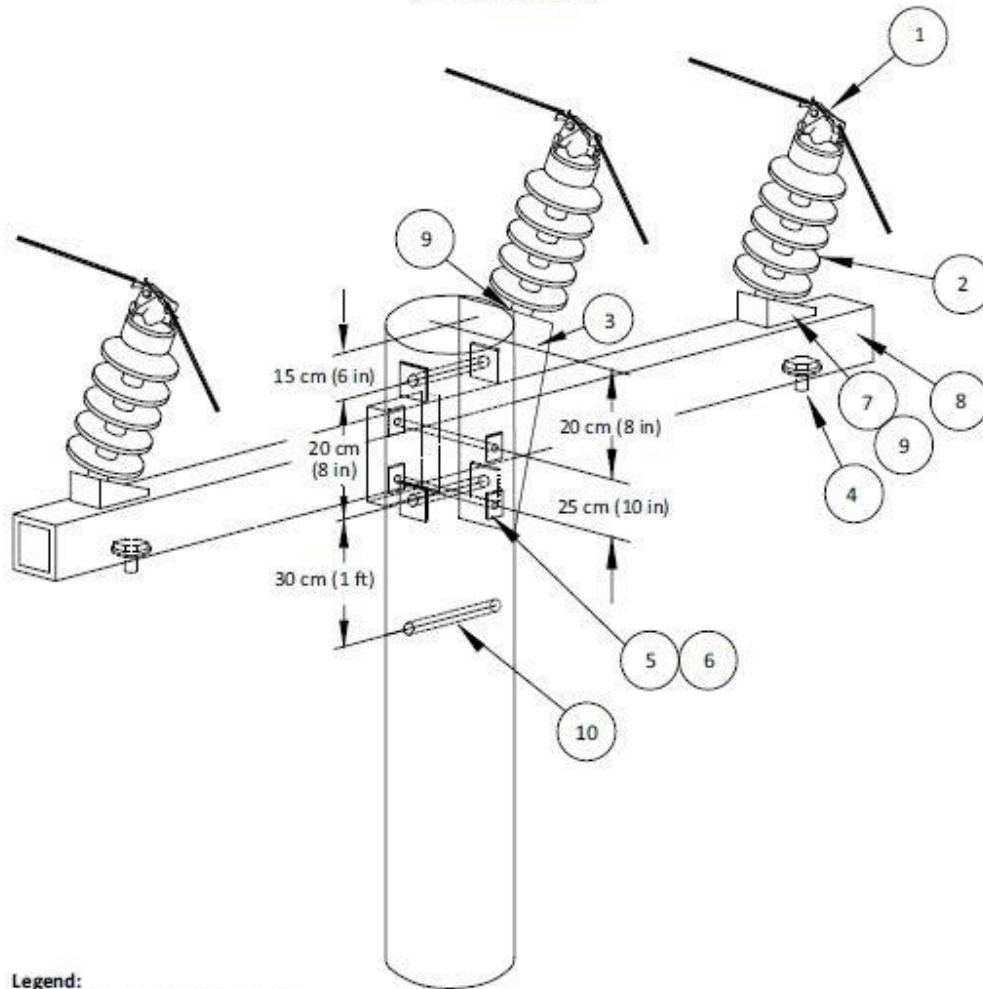

Legend:

- 1 = Clamp, conductor, insulator
- 2 = Insulator, vertical
- 3 = Bracket, pole top, angle
- 4 = Stud, insulator, 5/8 in × 7 in
- 5 = Bolt, 5/8 in
- 6 = Washer, square 5/8 in × 2 in × 2 in
- 7 = Bracket, insulator angle mount
- 8 = Crossarm, steel 290 cm (9 ft, 6 in)
- 9 = Stud, post insulator 5/8 in × 3 in
- 10 = Guy location

**The OESC 28th Edition
Proposals for Ontario Amendments**

Subtransmission
-Primary 3-phase dead-end, crossarm (triangular), 44 kV
(See Rule 75-200.)

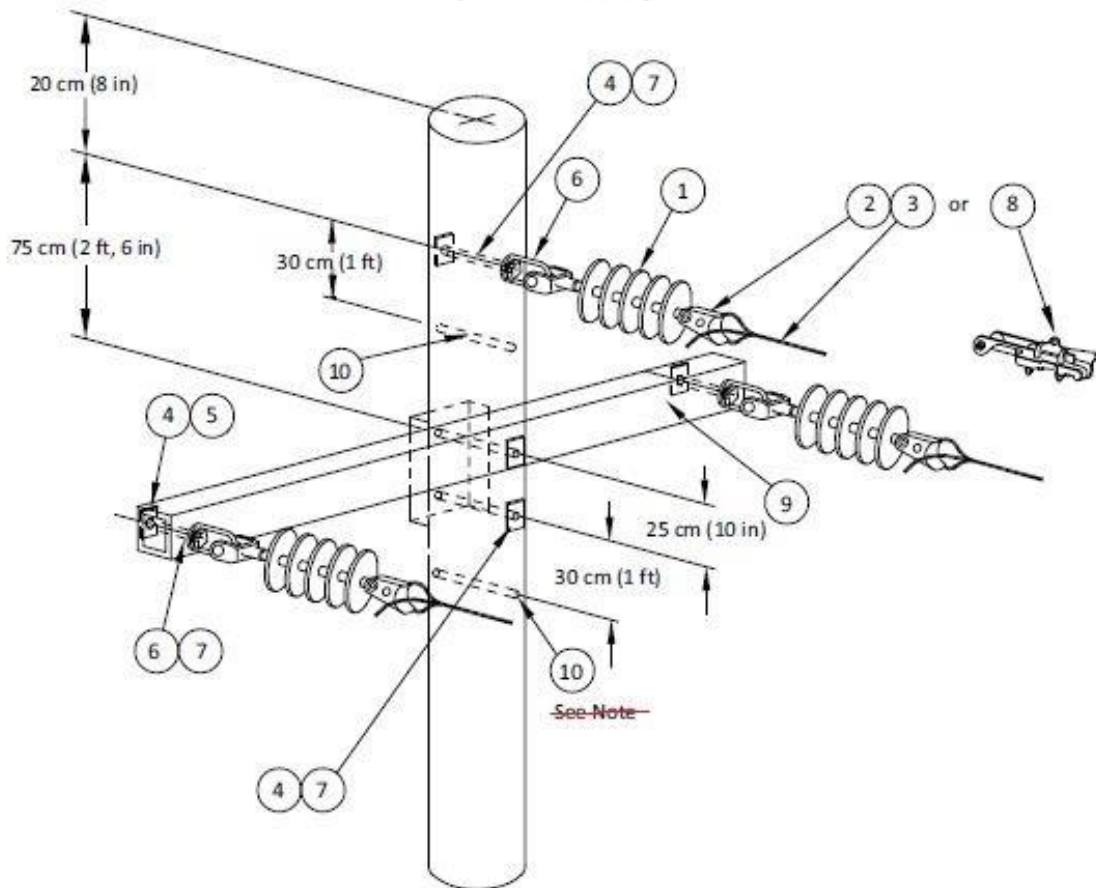

Legend:

- 1 = Insulator, dead-end
- 2 = Clevis bail, dead-end
- 3 = Grip, conductor, preformed, dead-end
- 4 = Washer, square 5/8 in × 2 in × 2 in
- 5 = Lockwasher, 5/8 in
- 6 = Oval eye for 5/8 in bolt
- 7 = Bolt, 5/8 in
- 8 = Clamp, conductor, bolted, dead-end
- 9 = Crossarm, steel (see span)
- 10 = Guy location

For maximum span	Crossarm
75 m (250 ft)	170 cm (5 ft, 6 in)
90 m (300 ft)	230 cm (7 ft, 6 in)

Note: *Guy under crossarm not required if conductors utilized are 1/0 AWG or smaller.*

**The OESC 28th Edition
Proposals for Ontario Amendments**

Subtransmission

Specification 18.4

Primary 3-phase dead-end, crossarm (flat), 44 kV
(See Rule 75-200.)

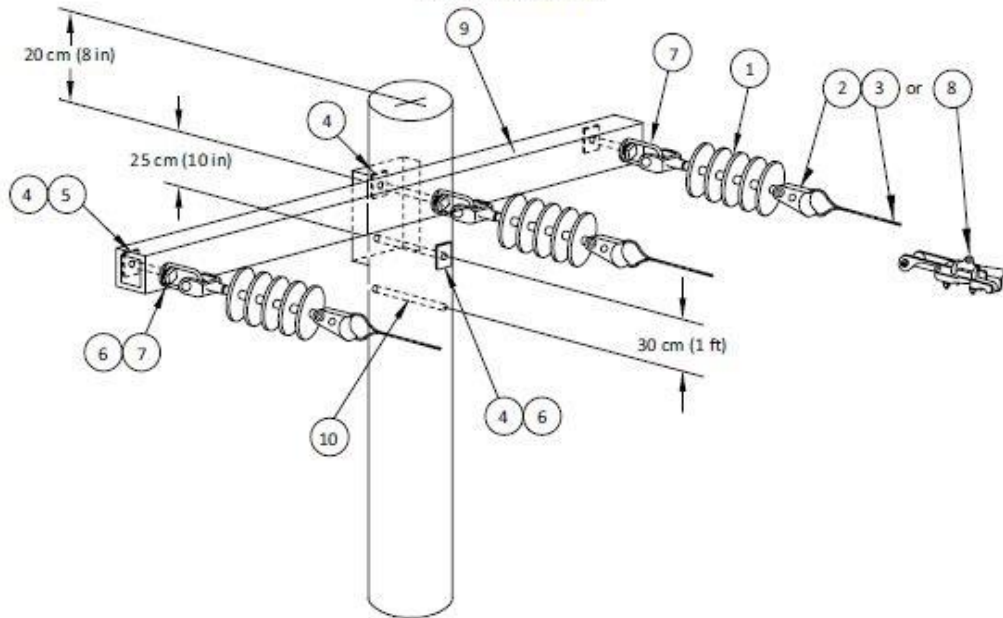

Legend:

- 1 = Insulator, dead-end
- 2 = Clevis bail, dead-end
- 3 = Grip, conductor, preformed, dead-end
- 4 = Washer, square 5/8 in x 2 in x 2 in
- 5 = Lockwasher, 5/8 in bolt
- 6 = Bolt, 5/8 in
- 7 = Oval eye for 5/8 in bolt
- 8 = Clamp, conductor, bolted, dead-end
- 9 = Crossarm, steel (see span)
- 10 = Guy location

For maximum span	Crossarm
75 m (250 ft)	230 cm (7 ft, 6 in)
90 m (300 ft)	290 cm (9 ft, 6 in)

Proposal Number: 2021-OA-012

Rule 75-306

Description of Change: Amend current Ontario Amendment to Rule 75-306 to include minimum breaking load

Submitted by: Section 75 Committee

Background:

Some installers were misinterpreting the term “Grade” for “Grade of Construction”. Revised to provide clarity to the requirement within the rule.

Rationale:

Grade used in this rule is in relation to the “minimum breaking load” of a guy wire. This differs from Grade used in Rule 75-308 where it specifies “Grade 1 construction” which is in relation to the design classification strength of a structure on applications when crossing a highway or railway tracks.

Added the imperial version into the rule since they are two different sizes as identified in the CSA G12-92 standard.

Proposed Change:

75-306 Guy wires and guards (see Appendix B)

- 1) Guy wires shall
 - a) be of 7-strand steel;
 - b) have a diameter of at least 9 mm (~~3/8 in~~), Grade 1300 **minimum breaking load of 61 kN or { 3/8 inch Grade 180 minimum breaking load of 13 500 lbs}**; and
 - c) be Class B coating weight galvanized.
- 2) Guy guards shall be installed at all locations.
- 3) The guy guard shall be made of plastic and shall be coloured bright yellow to provide good visual identification for public safety.
- 4) Two guy guards shall be installed one above the other on the same guy at locations used for winter recreation activities in heavy snow areas.
- 5) Where two or more guys are attached to one anchor, a guy guard shall be installed on both the innermost and outermost down guys.

Proposal Number: 2021-OA-013

New Rule 75-406

Description of Change: Revised Ontario Amendment Rule 75-406 to clarify different attachment methods for neutral conductors on poles

Submitted by: Section 75 Committee

Background:

Revised Rule and Specification 35 and added new Specification 35.1 to identify attachment methods on poles.

Rationale:

Rule now recognizes neutral conductor attachment methods on poles. Figure 2, neutral spool attachment on pole moved to new Specification 35.1.

Specification 35.1 created to show the different neutral attachments on poles.

Proposed Change:

75-406 Attachment of secondary service and neutral conductors

- 1) Secondary service conductors shall
 - a) terminate on a dead-end rack of a type shown in Specification 35; or
 - b) be attached to a pole in accordance with Specification 36, 37, 38, or 39.
- 2) Neutral conductors shall be attached to a pole in accordance with Specification 35.1.

The OESC 28th Edition
Proposals for Ontario Amendments

Specification 35
Details of secondary service rack ~~or neutral spool~~
[See Rule 75-406 1) a) and Appendix B Note to Rule 6-112 1).]

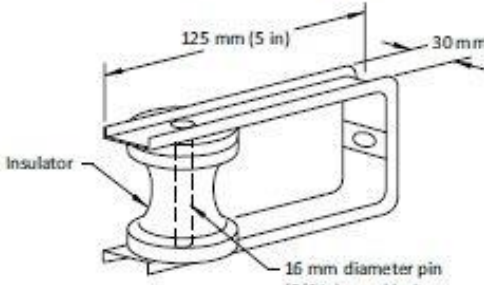

Figure 1
One-wire rack

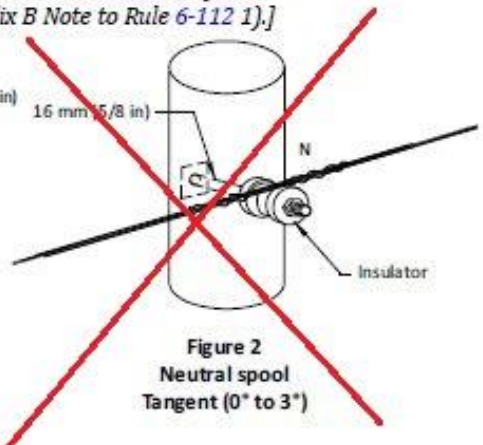

Figure 2
Neutral spool
Tangent (0° to 3°)

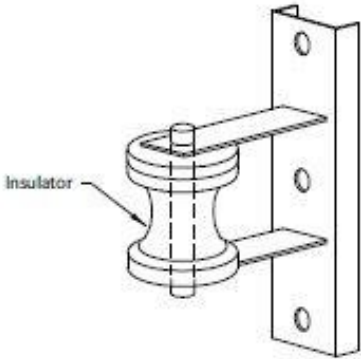

Figure 2
One-wire rack

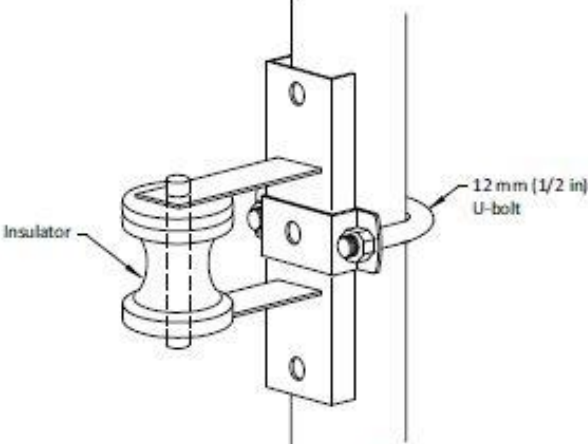

Figure 3
One-wire rack
(mounted to service mast)

The OESC 28th Edition Proposals for Ontario Amendments

Specification 35.1

Details of neutral pole attachment
See Rule 75-406.2)

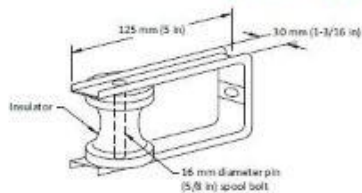

Figure 1
One-wire rack
Dead-end spool
Tangent (0 deg to 3 deg)

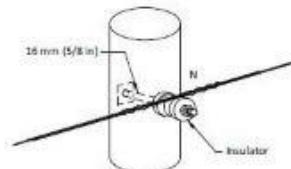

Figure 2
Neutral spool
Tangent (0° to 3°)

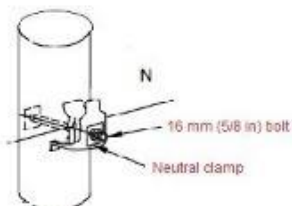

Figure 3
Neutral clamp
Tangent (0 deg to 3 deg)
Angle (4 deg to 15 deg)

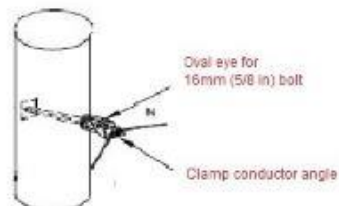

Figure 4
Neutral clamp angle
(15 deg to 60 deg)

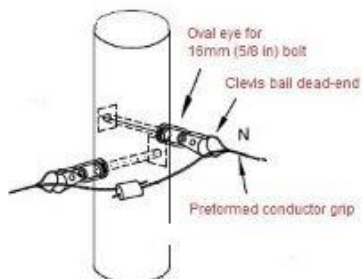

Figure 5
Dead-end corner
(51 deg to 90 deg)



Figure 6
Dead-end corner
(81 deg to 90 deg)

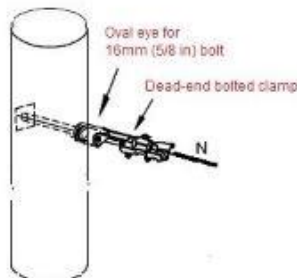

Figure 7
Dead-end

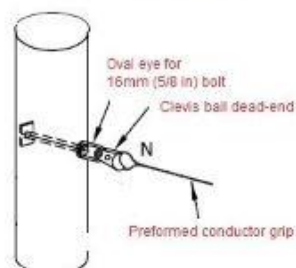

Figure 8
Dead-end

Proposal Number: 2021-OA-014

New Rule 75-504

Description of Change: Revised Ontario Amendment Rule 75-504 to recognize other approved methods to connect conductors

Submitted by: Section 75 Committee

Background:

Amended rule to recognize other approved methods of connecting conductors. Shear bolt connectors allows the connector to be installed onto the conductor without the need for a torque wrench. The bolts shear off at the appropriate torque specification. These products are readily available and doesn't require any specific tools to install. Some also provide weather tight and insulated connections.

<https://www.sicameusa.com/medium-voltage-overhead-1>

https://www.3mcanada.ca/3M/en_CA/company-ca/all-3m-products/~3M-Mechanical-Shearbolt-Connector-QCI-2-250-2-AWG-250-kcmil/?N=5002385+3293277382+3294529206&rt=rud

http://www.nexans-power-accessories.com/fileadmin/Kataloge/english/NPAG_Shearbolt_connectors_en.pdf

Proposed Change:

75-504 Connections

Connectors for all **primary** overhead current-carrying connections shall be compression, **or** wedge **type** or **shear bolt type**.

Proposal Number: 2021-OA-015

Rule 75-604

Description of Change: Revised Rule 75-604 to provide sag of quadruplex conductors.

Submitted by: Section 75 Committee

Background: Revising this rule will help alleviate stray voltage concerns on buildings housing livestock. It provides an option for the installer or farmer at other buildings not to establish neutral grounding at the service box supplied from a central metering system.

Rationale: Revised heading of Table 105 to clarify the table is for triplex conductors since the addition of quadruplex conductors.

Table 106 added to include sags and tensions for quadruplex conductors.

Proposed Change:

**The OESC 28th Edition
Proposals for Ontario Amendments**

75-604 Sag between poles or between poles and buildings

Open wire bus, neutral-supported cable, and ACSR shall be installed so that the sag of the conductors between poles or between poles and a building is determined by using Tables 105 or Tables 107 to 112, whichever is applicable to the size and type of conductor being installed and with respect to applicable span and temperature.

Table 105
Sag of neutral-supported ~~cable~~ triplex cable
(ruling span* — 30.0 m)
(See Rule 75-604.)

Temp. °C	Triplex: 2-No. 4 Polyethylene AL. 1-No. 4 Bare ACSR				Triplex: 2-No. 2 Polyethylene AL. 1-No. 2 Bare ACSR				Triplex: 2-No. 1/0 Polyethylene AL. 1-No. 1/0 Bare ACSR			
	Span, m				Span, m				Span, m			
	15	23	30	38	15	23	30	38	15	23	30	38
Temp. °C	Sag, mm				Sag, mm				Sag, mm			
-29	127	279	508	787	203	432	762	1194	254	584	1016	1575
-18	152	330	559	838	203	457	813	1270	279	584	1041	1626
0	152	356	635	914	229	483	864	1346	279	610	1092	1702
16	178	406	711	1118	229	533	940	1473	279	635	1143	1778
32	203	432	762	1194	254	559	991	1549	305	660	1168	1829

Temp. °C	Triplex: 2-No. 3/0 Polyethylene AL. 1-No. 1/0 Bare ACSR				Triplex: 2-No. 4/0 Polyethylene AL. 1-No. 3/0 Bare ACSR			
	Span, m				Span, m			
	15	23	30	38	15	23	30	38
Temp. °C	Sag, mm				Sag, mm			
-29	305	686	1194	1880	406	889	1600	2489
-18	305	686	1219	1905	406	914	1626	2540
0	305	711	1245	1956	406	940	1651	2591
16	330	711	1270	1981	432	940	1676	2616
32	330	737	1321	2057	432	965	1727	2692

* Ruling span formula:
Ruling span = average span + 2/3 (maximum span — average span)

**The OESC 28th Edition
Proposals for Ontario Amendments**

Table 106
Sags and tensions for pre-assembled
Quadruplex cable
(ruling span*-30m)
(see Rule 75-604)

Temp. (deg C)	# No. 1/0 AL 600 V (Neut. # No.1/0 Bare ACSR)				# No. 3/0 AL 600 V (Neut. # No. 3/0 Bare ACSR)			
	Span (m)				Span (m)			
	15	23	30	38	15	23	30	38
	Sag (em mm)				Sag (em mm)			
-29	220	520	880	1410	210	610	1110	1840
-20	230	540	920	1470	240	640	1140	1870
0	250	580	990	1590	290	690	1190	1930
16	260	610	1040	1670	330	730	1230	1970
32	270	640	1090	1740	360	770	1270	2010

*Ruling span formula:

$Ruling\ span = average\ span + 2/3\ (maximum\ span - average\ span)$

Proposal Number: 2021-OA-016

Rule 75-710

Description of Change: Amend current Ontario Amendment to Rule 75-710 to include of new structures under or near existing customer owned powerlines

Submitted by: Section 75 Committee

Background:

Scope of Section 75 applies to the installation of customer owned primary and secondary lines (powerlines). When a customer installs an overhead powerline, they are required to meet the applicable clearances from existing buildings or structures on the property as per Rule 75-708 and 75-710. However when installing a new structure such as an entertainment tent or flag pole near or under an existing customer owned overhead powerline, Rule 75-710 would not apply since the rule does not indicate the clearances are to be maintained once the powerlines have been installed.

The installation of a structure such as event tents may pose electrical shock hazards to the installers or public during and after the installation. Their typical setup and taken down schedules are short and often involve installers working long hours, many times after sundown and/or in poor weather conditions, further increasing the chances of a contact. Additionally, direct contact with the metallic tent pole doesn't have to occur for a member of the public or a worker to receive an electrical shock; an arc may occur under the right conditions if the tent pole is erected in close proximity to the overhead powerline.

Five members of a crew setting up an outdoor tent received electric shocks when a tent pole they were erecting made contact with a 4.8 kV customer overhead power line. One victim succumbed to his injuries, three suffered critical injuries and one non-critical injury.



Entertainment tent contact –fatality & multiple injuries

The OESC 28th Edition Proposals for Ontario Amendments



Fair tent set up under overhead powerlines



Carnival tent set up under overhead powerlines

Another incident involved a 19 year old worker was tasked to replace the flags on the flag poles with the use of a scissor lift. The existing flag poles were directly under the customer owned 27.6 kV lines. While a loft in the lift and in the process of changing the flags, the flag pole contacted the primary line resulting in the worker succumbing to his injuries.



Fatality involving a young worker

The OESC 28th Edition Proposals for Ontario Amendments

Rationale:

When an ESA inspector identifies a location where a structure is in close proximity to an overhead customer owned* powerline, the inspector cannot issue a defect against the property owner to have the issue resolved.

() Note: If a structure was placed in close proximity to a utility owned overhead powerline, we do have utility public safety concern process through Ontario Reg. 22/04 Electrical Distribution Safety Regulation to which a utility public safety concern letter is sent to the utility and they will work with the customer to have the structure removed or the powerlines relocated.*

The proposal introduces the addition of clearances to be “maintained” around overhead powerlines. Currently the OESC has other rules requiring an owner to **maintain** clearances around equipment. For example:

- **Rule 2-308 Working space around electrical equipment**
 - 1) A minimum working space of 1 m with secure footing shall be provided and **maintained** about electrical equipment that contains renewable parts, disconnecting means, or operating means; or requires examination, adjustment, operation, or maintenance
- **Rule 2-312 Transformer working space**

Except as provided for in Rule 26-242 and notwithstanding Rules 2-308 and 2-310, for transformers rated greater than 50 kVA, a minimum horizontal working space of 1 m shall be provided and **maintained** on the sides of the transformer that provide access to conductor connections.
- **Rule 36-110 Guarding of live parts and exposed conductors**
 - 1) Bare conductors, insulated conductors unless enclosed in or in contact with grounded metal, and other bare live parts shall be
 - a) accessible only to authorized persons; and
 - b) isolated by elevation or by barriers.
 - 2) Where the conductors or live parts mentioned in Subrule 1) are isolated by elevation, the elevations and clearances **maintained** shall be as specified in Tables 32, 33, and 34, except that
 - a) for voltages in excess of those specified in Tables 32, 33, and 34, the elevations and clearances **maintained** shall be in accordance with the requirements of CSA C22.3 No. 1; and
 - b) for conductors crossing highways, railways, communication lines, and other locations not covered in this Code, the elevations and clearances **maintained** shall be in accordance with the requirements of CSA C22.3 No. 1 or the applicable standard, whichever are greater.
 - 3) For a given span, the clearances specified in Table 34 shall be increased by 1% of the amount by which the span exceeds 50 m.

The OESC 28th Edition Proposals for Ontario Amendments

- **Rule 75-700 Clearances between power conductors and communication circuits**
*1) Electrical equipment, power conductors, communication circuits, and equipment shall be constructed and **maintained** so as to create no undue hazard to previously installed facilities.*
- **Rule 75-712 Tree Trimming**
*All trees and woody growth adjacent to a line shall be trimmed and **maintained** so that a minimum clearance to the nearest conductor, measured radially from the conductor at rest, is*
 - a) 1 m for secondary lines; and*
 - b) 4 m for primary lines.*

Other regulations such as the Ontario Building Code (OBC) does not contain clearance requirements from structures to overhead powerlines. Subsection 3.1.19 contains clearances from new buildings (includes Part 3 exceeding three storeys and Part 9 three or fewer storeys) to existing above ground electrical conductors. Additionally, Subsection 3.15.5.2 clearance for exterior signs is required to meet the new building clearance in Subsection 3.1.19. For tents, air supported structures or flag poles, the OBC has no clearance requirements to existing overhead powerlines.

Other standards such as CAN/CSA 22.3 No.1 Overhead Systems applies to electric supply and communication lines and equipment located outside of buildings employed by a utility.

In 2017, ESA had submitted a code proposal to the CEC Section 66 technical subcommittee to address this requirement, however it is still under review. Since ESA has been seeing fatalities resulting from structures placed near or under overhead powerlines, amending Rule 75-710 will be used as a mechanism to defect a property owner when a structure is found near or under and customer owned overhead powerline. ESA's 2020-2025 strategic plan's goal 1 is to further reduce electrical related harm such as powerline contacts.

The OESC 28th Edition Proposals for Ontario Amendments

Proposed Change:

75-710 Clearances ~~between of~~ conductors ~~from and other~~ structures (see Appendix B)

~~4)~~ Notwithstanding Rule 36-110, ~~clearances between~~ conductors of an overhead primary line ~~or secondary line and temporary or permanent structures~~ shall ~~be installed and maintained as to~~ meet the minimum clearances ~~from a structure~~ specified in Rule 75-708 ~~1), 2), and 3),~~ and

- a) not be located closer than 12 m measured horizontally from silos to the closest conductors, with the conductor at rest;
- b) not be located closer than 12 m measured horizontally over wells from which pump rods may be lifted and come in contact with the conductors at rest;
- c) except for free-standing engineered structures, have sufficient clearance from free-standing poles that support flood or area lighting, signs, flagpoles, antennae, or other similar structures so as to permit the structure to fall in an arc without touching the conductors at rest;
- d) not be located within 6 m, measured horizontally from **windmills wind driven** or similar structures, to the closest conductor, with the conductor at rest; and
- e) have a minimum vertical clearance of 3.1 m above fencing at maximum sag.

~~2) A overhead secondary line conductor shall meet the minimum clearance requirements of Rule 75-708 3) and 4).~~

Appendix B

Rule 75-710

Structures **may includes but not limited to;** flood lighting poles, signs, flagpoles or other high reach objects, mobile homes, trailers, tents and amusement devices used for events such as carnivals and entertainment.

Rule 75-710 1) c)

Free-standing engineered structures are structures such as wind turbines, communication towers, and transmission towers, which are engineered to self-support and do not rely on lateral supports.

**The OESC 28th Edition
Proposals for Ontario Amendments**

Proposal Number: 2021-OA-017

Rule 75-902

Description of Change: Revised Rule 75-902 to recognize ground mounted central metering systems.

Submitted by: CM system working group

Background: There has been an increased number of underground customer owned primary installations to an embedded supply authority's pad mounted transformer.

Rationale: Amended rule since central metering systems can be either pole mounted or padmounted. There are no rules in the OESC that will permit the central metering system to be supplied from a pad mounted transformer.

Proposed Change:

The OESC 28th Edition Proposals for Ontario Amendments

75-902 Central metering system (CMS) (See Appendix B)

The following requirements shall apply to the central metering system (CMS):

- a) ~~A standard pole-mounted distribution transformer without a secondary breaker or pole-mounted switch~~ Permitted to be used to supply multi-service installations when
- i) there is no customer-owned equipment between the ~~supply authority's embedded transformer (s) and the demarcation point supply authority interface~~ (excluding surge arresters and conductor); and
 - ii) written assurance has been received from a supply authority stating it owns and controls the ~~embedded transformer (s)~~.
- b) Each building shall have a disconnecting means, and where the disconnecting means is a service box, it shall be installed as per Section 6.
- c) Voltage drop of the service conductors from the transformer to the service box shall meet the requirements of ~~not exceed 3% based on 80% of the service switch or a calculated load as per~~ Section 8.
- e) d) ~~New~~ Overhead ~~wire~~ wiring shall; be
- i) ~~be~~ neutral-supported cable with a minimum of No. 2 AWG aluminum; ~~and,~~
 - ii) ~~when parallel conductors are installed, shall~~ comply with Rule 12-108 ~~when parallel conductors are installed; and or~~
 - ii) iii) ~~notwithstanding Item c) i), for over 200 A, open wire bus shall~~ be permitted ~~where circuit ampacity exceeds 200 A. as open wire for over 200 A.~~
- e) e) The minimum ampacity of overhead or underground conductors feeding more than one service or building shall be based on 80% of the sum of the ratings of all service boxes supplied.
- e) f) Transformer pole hardware and metering equipment shall be in accordance with Specifications 41, 42, and 43.
- g) pad mounted installations shall ~~be in accordance with Specification 41.1.~~ ~~meet the requirements of the supply authority.~~
- f) h) CMS-type ~~service systems~~ shall not have more than four ~~subdivisions~~ services ~~of the service~~ extending from a transformer pole.

The OESC 28th Edition Proposals for Ontario Amendments

Add new Appendix B 75-902 g) as follows:

Shown below is an example of a pad mounted central metering installation.

Figure B75-1 Central metering system- pad mounted installation

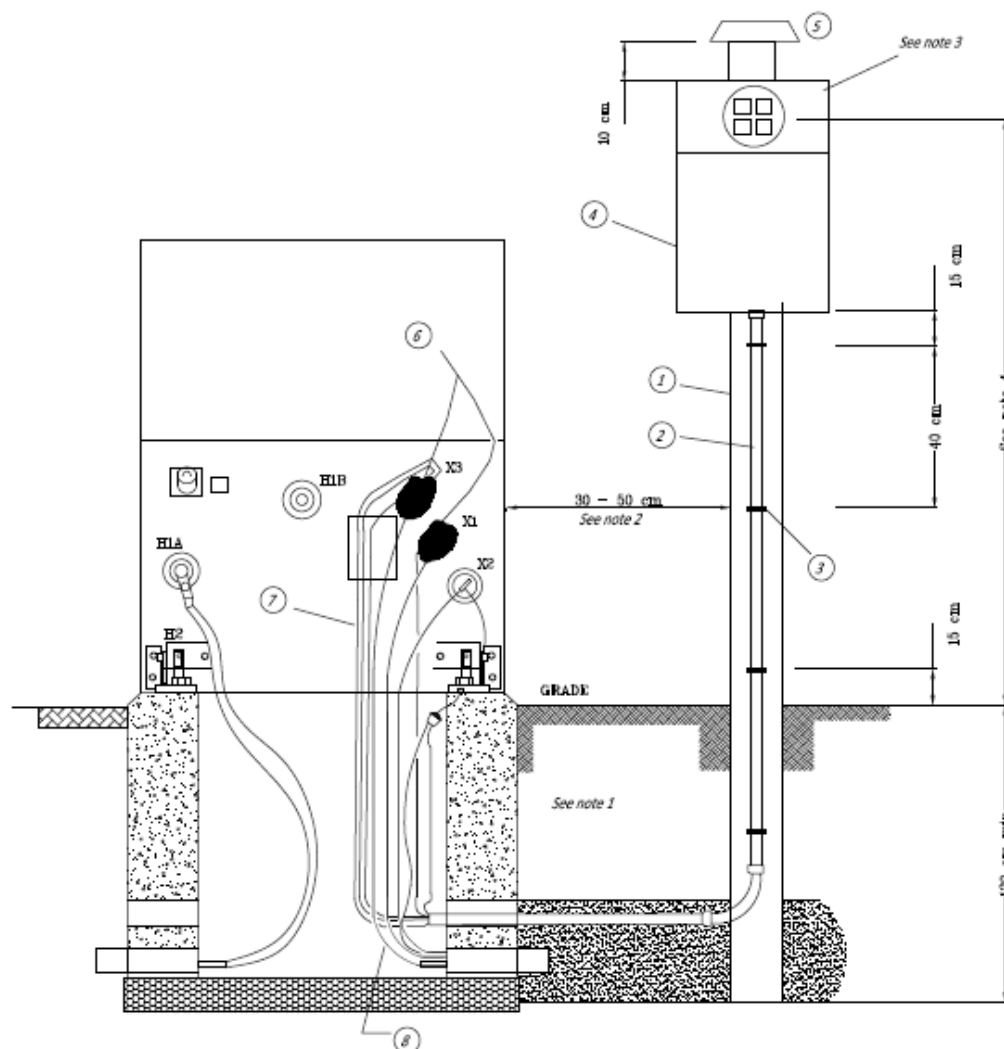

Legend

- 1 = 6 in x 6 in x 10 ft pressure treated post
- 2 = 1/2 in PVC conduit
- 3 = cable straps
- 4 = approved meter base
- 5 = post cap
- 6 = current transformers
- 7 = wiring for metering No. 12 copper. Colour coding and number of conductors shall be as required by the supply authority
- 8 = consumer service conductors

Notes:

- 1. Foundation installation determined by the supply authority.
- 2. Meter base installed inside the ground gradient loop. Bond meter base to transformer ground loop.
- 3. Meter base type to be determined by the supply authority.
- 4. Height of meter base to finished grade determined by the supply authority.

The OESC 28th Edition Proposals for Ontario Amendments

Proposal Number: 2021-OA-018

Rule 75-904

Description of Change: Revised Rule 75-904 to allow other methods to install a transfer device.

Submitted by: CM system working group

Background: With the current industry practice and addition of padmounted transformers and central metering to section 75, requests have been made to install ground mounted transfer devices. Currently the OESC does not recognize central metering ground mounted installations with direct access to grade.

Rationale: Amended Rule permitting transfer devices can also be ground mounted. The proposal will recognize the ground mounted transfer device will be permitted to be installed before the service box or after the service box. If the installed ahead of the service box, then Section 6 requirements are to be met including the transfer device to contain integral overcurrent protection.

Proposed Change:

75-904 Pole-top Transfer devices for CMS

~~Pole-top transfer devices shall be installed to the following requirements:~~

- ~~a) the transfer device shall be approved for the purpose;~~
- ~~b) the minimum rating of a transfer device shall be equal to or greater than 80% of the sum of all service boxes supplied; and~~
- ~~c) the minimum clearances on the pole shall be those shown on Specification 41~~

1) Installation of ground mounted transfer devices shall meet the requirements of Section 6.

2) Pole-top mounted transfer devices for CMS shall:

- a) have a minimum **ampacity** rating equal to or greater than 80% of the sum of all service boxes supplied;
- b) meet the minimum clearances shown on Specification 41; **and**
- c)** be permitted to be installed ahead of the service box without integral overcurrent protection, provided that it has a withstand rating equal to or greater than the available fault current levels; **and**
- d) in compliance with the requirements of the supply authority.**

**The OESC 28th Edition
Proposals for Ontario Amendments**

Proposal Number: 2021-OA-019

Specification 28

Description of Change: Revised current Ontario Amendment Specification 28

Submitted by: Section 75 Committee

Background:

Revised Specification 28 to align with Rule 6-302 for different wiring methods.

Rationale:

Clarifies the requirements to remove any contradiction between the wiring methods in Rule 6-302 and the Specification which illustrates rigid metal conduit only.

**The OESC 28th Edition
Proposals for Ontario Amendments**

Proposed Change:

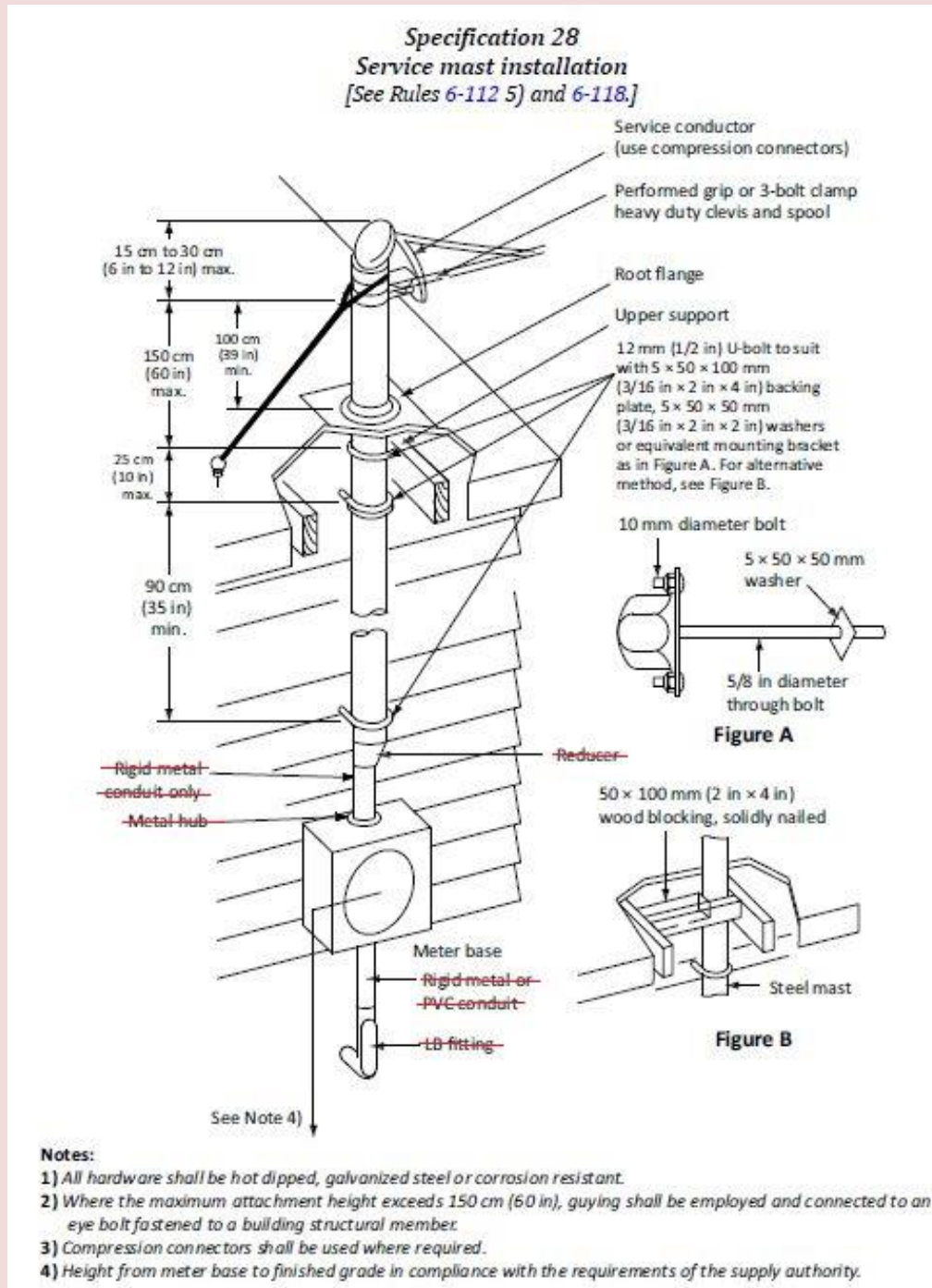

Proposal Number: 2021-OA-020

Specification 34

Description of Change: Revise current Ontario Amendment Specification 34 to include other grounding electrodes

Submitted by: Section 75 Committee

Background:

Revised specification to include pole butt plates and general revision

Rationale:

Revised item number two to clarify the grounding conductor size for primary voltages up to 27.6kV 3-phase/4-wire systems.

Revised item number three to include 3-phase/3-wire systems for primary voltages up to 44kV. Other voltages such as 27.6kV can be distributed as ungrounded.

Revised item number ten to now include pole butt ground plates. Ground electrodes are manufactured to meet the requirements of CSA C22.2 No.41 as identified in Appendix B note for Rule 10-102.

Proposed Change:

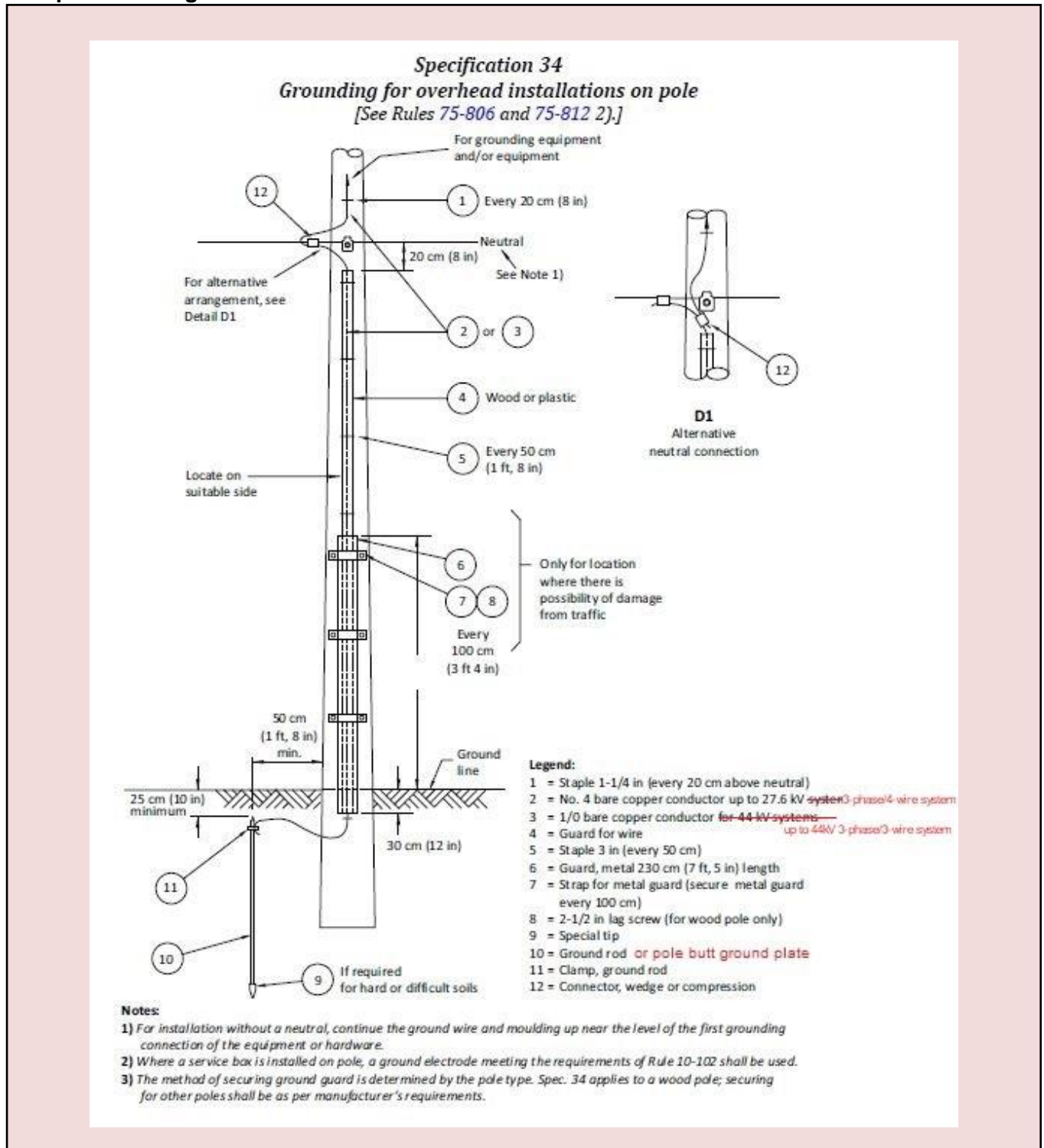

**The OESC 28th Edition
Proposals for Ontario Amendments**

Proposal Number: 2021-OA-021

Specification 45

**Description of Change: Revise current Ontario Amendment Specification 45-
editorial**

Submitted by: Section 75 Committee

Background & Rationale:

Editorial revision to remove crimped connector. This was missed on the previous code edition during the file conversion.

Proposed Change:

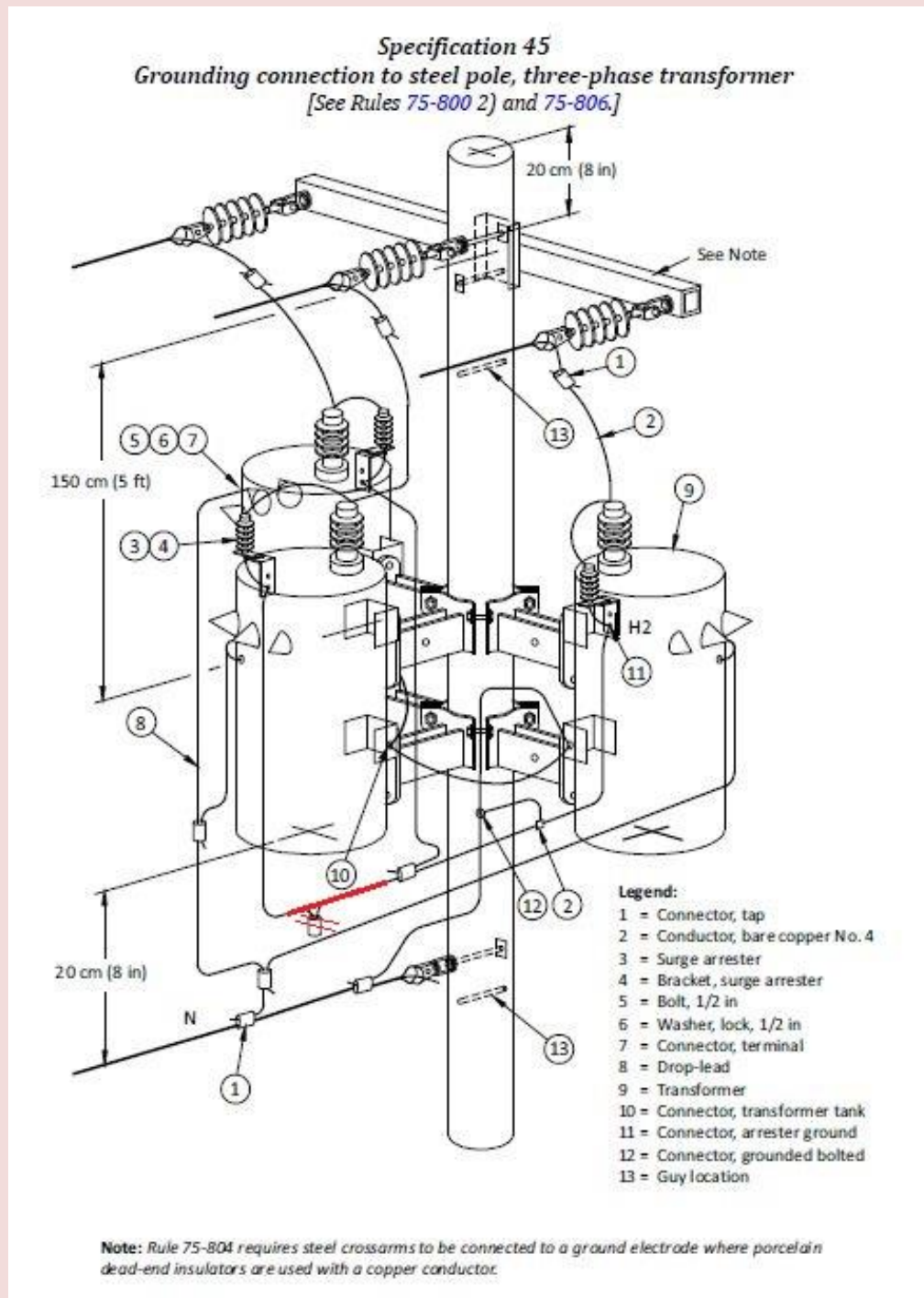

Proposal Number: 2021-OA-022

Appendix I

Description of Change: Delete Appendix I from Ontario Electrical Safety Code

Submitted by: Electrical Safety Authority

Background

Appendix I is informative part of the Code, which means it is non-mandatory. It represents Committee interpretations of the Canadian Electrical Code in form of Questions and Answers. It is based on the Rules in the previous version of the Code, which means that Appendix I in the 2021 CE Code will be based on Rules in the 2018 Code.

Rationale

Many provided answers on questions in Appendix I are in contradiction with the amended Rules in CE Code. Very often, after Request for Interpretation has been provided to the Subcommittee, the referenced rule has been amended to provide clarifications.

Example 1:

- Rule 8-304 2) has been amended in the 2021 CE Code to clarify that when a receptacle is used as an outlet for the application of Subrule 1), it shall be considered as 1 outlet per duplex receptacle, 1.5 outlets per triplex receptacle, and 2 outlets per quadruplex receptacle.

- However, Appendix I in the 2021 CE Code include the following questions:

Rule 8-304 1)

Question: For the application of Rule 8-304 1), is a duplex receptacle considered as one outlet?

Answer: Yes.

Question: For the application of Rule 8-304 1), is a quadruplex receptacle considered as one outlet?

Answer: Yes.

Example 2:

- Rules 4-024 and 4-032 have been amended in the 2021 CEC Code to require all insulated neutral conductors that are required to be identified, to be with a white covering.
- However, Appendix I in the 2021 CEC Code include the following question:

The OESC 28th Edition Proposals for Ontario Amendments

Rules 4-024 and 4-032

Question: Do Rules 4-024 and 4-032 mandate that insulated conductors coloured white or grey shall only be used as a neutral conductor or an identified conductor?

Answer: Yes.

The contradiction between Appendix I interpretations and Code requirements will be confusing to the contractors and other Code users and will increase burden to industry. In addition, ESA as the AHJ in Ontario enforcing OESC, has been providing the industry with the necessary clarification and interpretations by publishing bulletins. OESC bulletins are available for all code purchasers free of charge. If any clarification is needed based on Appendix I, it could be added in Bulletins.

Proposed Change:

Delete Appendix I

Appendix I — Interpretations

~~[See Clauses C9.12 b) and C9.13]~~

Notes:

- ~~1) This Appendix is an informative (non-mandatory) part of this Code.~~
- ~~2) Committee interpretations of the Canadian Electrical Code, Part I, are available on the Current Standards Activities page at standardsactivities.csa.ca.~~
- ~~3) The interpretations in this Appendix are based on Rules in the 2018 Code. Rule numbering and content in the 2021 Code may differ from the 2018 edition.~~

Rule 4-006 1)

Question: In accordance with the new note in Table 5A, “** The insulation temperature rating is the temperature marked on the conductor”, if a circuit breaker rated with a maximum conductor termination of 75 °C has TECK 90 connected to it to feed a piece of equipment that is marked with a maximum conductor termination of 75 °C, yet partway through the cable run, the TECK 90 goes through an area with an ambient exceeding 30 °C, would we use the 90 °C column of Table 5A so long as the high ambient area is more than 1.2 m away from the equipment in accordance with Rules 4-006 1) and 4)?

Answer: Yes.

Rules 4-024 and 4-032

Question: Do Rules 4-024 and 4-032 mandate that insulated conductors coloured white or grey shall only be used as a neutral conductor or an identified conductor?

Answer: Yes.

Rule 8-304 1)

Question: For the application of Rule 8-304 1), is a duplex receptacle considered as one outlet?

Answer: Yes.

Question: For the application of Rule 8-304 1), is a quadruplex receptacle considered as one outlet?

Answer: Yes.

Rule 24-104 8)

Question: In accordance with the literal text of Rule 24-104 8), and in accordance with the Appendix B Note on this Subrule, is a metal sink located in a patient care environment required to be bonded to ground?

Answer: No.

The OESC 28th Edition Proposals for Ontario Amendments

~~Rule 36-204~~

~~Question:~~ Would a 66 kV load-break rated circuit switcher and associated protection relays be considered as a breaker/overcurrent protection to comply with Rule 36-204?

~~Answer:~~ No.

~~Rule 42-004~~

~~Question:~~ In accordance with Rule 42-004, is it permissible to install an overcurrent device with a rating or setting larger than the rating of the receptacle if the rating or type of the welder is unknown, provided that the overcurrent rating or setting adequately protects the conductors supplying the receptacle?

~~Answer:~~ No.

~~Rule 64-222 1)~~

~~Question:~~ If a racking system approved for use in Canada utilizes integrated bonding in its components in conjunction with modules approved for use with that racking system, would this be an acceptable means of bonding to ground as required by Rule 64-222 1)?

~~Answer:~~ Yes.

~~Rule 64-222 4)~~

~~Question:~~ In Rule 64-222 4), does the phrase "removal of a photovoltaic module" refer to a single photovoltaic module only?

~~Answer:~~ Yes.